

Nature of soil – phase relationships – Soil description and classification for engineering purposes, their significance – Index properties of soils - BIS Classification system – Soil compaction – Theory, comparison of laboratory and field compaction methods – Factors influencing compaction behavior of soils.

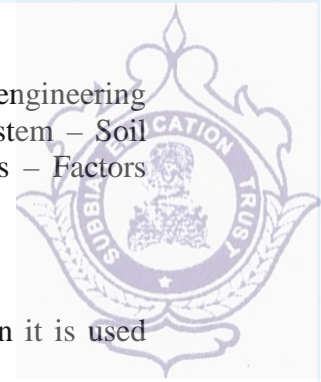

## Soil Mechanics

“Soil mechanics” is the study of the engineering behavior of soil when it is used either as a construction material or as a foundation material.

This is a relatively young discipline of civil engineering, systematized in its modern form by Karl Von Terzaghi (1925), who is rightly regarded as the “Father of Modern Soil Mechanics”. An understanding of the principles of mechanics is essential to the study of soil mechanics.

A knowledge and application of the principles of other basic sciences such as physics and chemistry would also be helpful in the understanding of soil behavior. Further, laboratory and field research have contributed in no small measure to the development of soil mechanics as a discipline.

### 1.1 Introduction

The term ‘Soil’ has different meanings in different scientific fields. It has originated from the Latin word *Solum*. To an agricultural scientist, it means “the loose material on the earth’s crust consisting of disintegrated rock with an admixture of organic matter, which supports plant life”. To a geologist, it means the disintegrated rock material which has not been transported from the place of origin. But, to a civil engineer, the term ‘soil’ means, and the loose unconsolidated inorganic material on the earth’s crust produced by the disintegration of rocks, overlying hard rock with or without organic matter. Foundations of all structures have to be placed on or in such soil, which is the primary reason for our interest as Civil Engineers in its engineering behavior.

Soil may remain at the place of its origin or it may be transported by various natural agencies. It is said to be ‘residual’ in the earlier situation and ‘transported’ in the latter. The application of the principles of soil mechanics to the design and construction of foundations for various structures is known as “Foundation Engineering”. “Geotechnical Engineering” may be considered to include both soil mechanics and foundation engineering.

In fact, according to Terzaghi, it is difficult to draw a distinct line of demarcation between soil mechanics and foundation engineering; the latter starts where the former ends.

### 1.2 DEVELOPMENT OF SOIL MECHANICS

The use of soil for engineering purposes dates back to prehistoric times. Soil was used not only for foundations but also as construction material for embankments. The knowledge was empirical in nature and was based on trial and error, and experience.

The hanging gardens of Babylon were supported by huge retaining walls, the construction of which should have required some knowledge, though empirical, of earth pressures. The large public buildings, harbours, aqueducts, bridges, roads and sanitary works of Romans certainly indicate some knowledge of the engineering behaviour of soil. This has been evident from the

Writings of Vitruvius, the Roman Engineer in the first century, B.C. Mansar and Viswakarma, in India, wrote books on ‘construction science’ during the medieval period.

JAIR The Leaning Tower of Pisa. It was built between 1174 and 1350 A.D., is a glaring example of a lack of sufficient knowledge of the behaviour of compressible soil, in those days.

Coulomb, a French Engineer, published his wedge theory of earth pressure in 1776, which is the first major contribution to the scientific study of soil behaviour. He was the first to introduce the concept of shearing resistance of the soil as composed of the two components—cohesion and internal friction. Poncelet, Culmann and Rebhann were the other men who extended the work of Coulomb. D' Arcy and Stokes were notable for their laws for the flow of water through soil and settlement of a solid particle in liquid medium, respectively. These laws are still valid and play an important role in soil mechanics. Rankine gave his theory of earth pressure in 1857; he did not consider cohesion, although he knew of its existence.

Boussinesq, in 1885, gave his theory of stress distribution in an elastic medium under a point load on the surface. Mohr, in 1871, gave a graphical representation of the state of stress at a point, called 'Mohr's Circle of Stress'. This has an extensive application in the strength theories applicable to soil. Atterberg, a Swedish soil scientist, gave in 1911 the concept of 'consistency limits' for a soil. This made possible the understanding of the physical properties of soil. The Swedish method of slices for slope stability analysis was developed by Fellenius in 1926. He was the chairman of the Swedish Geotechnical Commission. Prandtl gave his theory of plastic equilibrium in 1920 which became the basis for the development of various theories of bearing capacity. Terzaghi gave his theory of consolidation in 1923 which became an important development in soil mechanics. He also published, in 1925, the first treatise on Soil Mechanics, a term coined by him. (*Erd bau mechanik*, in German). Thus, he is regarded as the Father of modern soil mechanics'. Later on, R.R. Proctor and A. Casagrande and a host of others were responsible for the development of the subject as a full-fledged discipline. Fifteen International Conferences have been held till now under the auspices of the international Society of Soil Mechanics and Foundation engineering at Harvard (Massachusetts, U.S.A.) 1936, Rotterdam (The Netherlands) 1948, Zurich (Switzerland) 1953, London (U.K.) 1957, Paris (France) 1961, Montreal (Canada) 1965, Mexico city (Mexico) 1969, Moscow (U.S.S.R) 1973, Tokyo (Japan) 1977, Stockholm (Sweden) 1981, San Francisco (U.S.A.) 1985, and Rio de Janeiro (Brazil) 1989. The thirteenth was held in New Delhi in 1994, the fourteenth in Hamburg, Germany, in 1997, and the fifteenth in Istanbul, Turkey in 2001. The sixteenth is proposed to be held in Osaka, Japan, in 2005.

These conferences have given a big boost to research in the field of Soil Mechanics and Foundation Engineering

### **1.3 FIELDS OF APPLICATION OF SOIL MECHANICS**

The knowledge of soil mechanics has application in many fields of Civil Engineering.

#### **1.3.1 Foundations**

The loads from any structure have to be ultimately transmitted to a soil through the foundation for the structure. Thus, the foundation is an important part of a structure, the type and details of which can be decided upon only with the knowledge and application of the principles of soil mechanics.

#### **1.3.2 Underground and Earth-retaining Structures**

Underground structures such as drainage structures, pipe lines, and tunnels and earth-retaining structures such as retaining walls and bulkheads can be designed and constructed only by using the principles of soil mechanics and the concept of 'soil-structure interaction'.



Pavement Design may consist of the design of flexible or rigid pavements. Flexible pavements depend more on the subgrade soil for transmitting the traffic loads. Problems peculiar to the design of pavements are the effect of repetitive loading, swelling and shrinkage of sub-soil and frost action. Consideration of these and other factors in the efficient design of a pavement is a must and one cannot do without the knowledge of soil mechanics.

### 1.3.4 Excavations, Embankments and Dams

Excavations require the knowledge of slope stability analysis; deep excavations may need temporary supports 'timbering' or 'bracing', the design of which requires knowledge of soil mechanics. Likewise the construction of embankments and earth dams where soil itself is used as the construction material requires a thorough knowledge of the engineering behaviour of soil especially in the presence of water. Knowledge of slope stability, effects of seepage, consolidation and consequent settlement as well as compaction characteristics for achieving maximum unit weight of the soil *in-situ*, is absolutely essential for efficient design and construction of embankments and earth dams.

The knowledge of soil mechanics, assuming the soil to be an ideal material elastic, isotropic, and homogeneous material—coupled with the experimental determination of soil properties, is helpful in predicting the behaviour of soil in the field. Soil being a particulate and heterogeneous material, does not lend itself to simple analysis. Further, the difficulty is enhanced by the fact that soil strata vary in extent as well as in depth even in a small area. A thorough knowledge of soil mechanics is a prerequisite to be a successful foundation engineer. It is difficult to draw a distinguishing line between Soil Mechanics and Foundation Engineering; the later starts where the former ends.

## 1.4 SOIL FORMATION

Soil is formed by the process of 'Weathering' of rocks, that is, disintegration and decomposition of rocks and minerals at or near the earth's surface through the actions of natural or mechanical and chemical agents into smaller and smaller grains. The factors of weathering may be atmospheric, such as changes in temperature and pressure; erosion and transportation by wind, water and glaciers; chemical action such as crystal growth, oxidation, hydration, carbonation and leaching by water, especially rainwater, with time. Obviously, soils formed by mechanical weathering (that is, disintegration of rocks by the action of wind, water and glaciers) bear a similarity in certain properties to the minerals in the parent rock, since chemical changes which could destroy their identity do not take place.

It is to be noted that 95% of the earth's crust consists of igneous rocks, and only the remaining 5% consists of sedimentary and metamorphic rocks. However, sedimentary rocks are present on 80% of the earth's surface area. Feldspars are the minerals abundantly present (60%) in igneous rocks. Amphiboles and pyroxenes, quartz and micas come next in that order. Rocks are altered more by the process of chemical weathering than by mechanical weathering. In chemical weathering some minerals disappear partially or fully, and new compounds are formed.

The intensity of weathering depends upon the presence of water and temperature and the dissolved materials in water. Carbonic acid and oxygen are the most effective dissolved materials found in water which cause the weathering of rocks. Chemical weathering has the maximum intensity in humid and tropical climates.

'Leaching' is the process whereby water-soluble parts in the soil such as Calcium Carbonate, are dissolved and washed out from the soil by rainfall or percolating subsurface

JAIRUBA 'loam' soil in which near to Kuala Lumpur, is formed by leaching. Harder minerals will be more resistant to weathering action, for example, Quartz present in igneous rocks. But, prolonged chemical action may affect even such relatively stable minerals, resulting in the formation of secondary products of weathering, such as clay minerals—illite, kaolinite and montmorillonite. 'Clay Mineralogy' has grown into a very complicated and broad subject (Ref: 'Clay Mineralogy' by R.E. Grim).

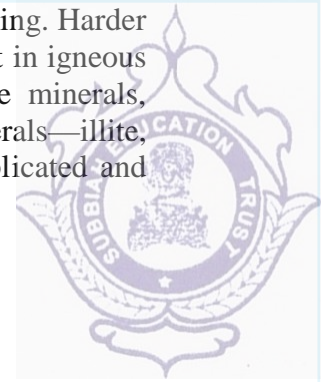

#### 1.4.1 Residual soils

To remain at the original place

- In Hong Kong areas, the top layer of rock is decomposed into residual soils due to the warm climate and abundant rainfall .
- Engineering properties of residual soils are different with those of transported soils

The knowledge of "classical" geotechnical engineering is mostly based on behavior of transported soils. The understanding of residual soils is insufficient in general

#### 1.4.2 Transported soils

To be moved and deposited to other places.

The particle sizes of transported soils are selected by the transportation agents such as streams, wind, etc.

Interstratifications of silts and clays.

The transported soils can be categorized based on the mode of transportation and deposition (six types).

- (1) **Glacial soils:** formed by transportation and deposition of glaciers.
- (2) **Alluvial soils:** transported by running water and deposited along streams.
- (3) **Lacustrine soils:** formed by deposition in quiet lakes (e.g. soils in Taipei basin).
- (4) **Marine soils:** formed by deposition in the seas (Hong Kong).
- (5) **Aeolian soils:** transported and deposited by the wind (e.g. soils in the loess plateau, China).
- (6) **Colluvial soils:** formed by movement of soil from its original place by gravity, such as during landslide (*Hong Kong*). (from Das, 1998)

#### 1.5 Soil Profile

A deposit of soil material, resulting from one or more of the geological processes described earlier, is subjected to further physical and chemical changes which are brought about by the climate and other factors prevalent subsequently. Vegetation starts to develop and rainfall begins the processes of leaching and eluviations of the surface of the soil material. Gradually, with the passage of geological time profound changes take place in the character of the soil. These changes bring about the development of 'soil profile'. Thus, the soil profile is a natural succession of zones or strata below the ground surface and represents the alterations in the original soil material which have been brought about by weathering processes. It may extend to different depths at different places and each stratum may have varying thickness.



JAIRUDAY, exhibits cohesion in dry condition, which is lost on wetting. Near vertical cuts can be made in the dry condition.



## 1.6.1 GEOTECHNICAL ENGINEERING

**Marl:** Mixtures of clacareous sands or clays or loam; clay content not more than 75% and lime content not less than 15%.

**Moorum:** Gravel mixed with red clay.

**Top-soil:** Surface material which supports plant life.

**Varved clay:** Clay and silt of glacial origin, essentially a lacustrine deposit; *varve* is a term of Swedish origin meaning thin layer. Thicker silt varves of summer alternate with thinner clay varves of winter.

## 1.7 STRUCTURE OF SOILS

The 'structure' of a soil may be defined as the manner of arrangement and state of aggregation of soil grains. In a broader sense, consideration of mineralogical composition, electrical properties, orientation and shape of soil grains, nature and properties of soil water and the interaction of soil water and soil grains, also may be included in the study of soil structure, which is typical for transported or sediments soils. Structural composition of sedimented soils influences, many of their important engineering properties such as permeability, compressibility and shear strength. Hence, a study of the structure of soils is important.

The following types of structure are commonly studied:

- (a) Single-grained structure
- (b) Honey-comb structure
- (c) Flocculent structure

### 1.7.1 Single-grained Structure

Single-grained structure is characteristic of coarse-grained soils, with a particle size greater than 0.02mm. Gravitational forces predominate the surface forces and hence grain to grain contact results. The deposition may occur in a loose state, with large voids or in a dense state, with less of voids.

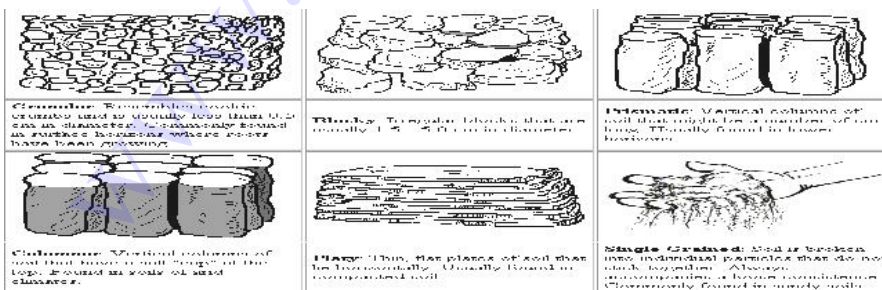

### 1.7.2 Honey-comb Structure

This structure can occur only in fine-grained soils, especially in silt and rock flour. Due to the relatively smaller size of grains, besides gravitational forces, inter-particle surface forces also play an important role in the process of settling down. Miniature arches are formed, which bridge over relatively large void spaces. This results in the formation of a honeycomb structure, each cell of a honey-comb being made up of numerous individual soil grains.

The structure has a large void space and may vary with high loads without a significant volume change. The structure can be broken down by external disturbances.

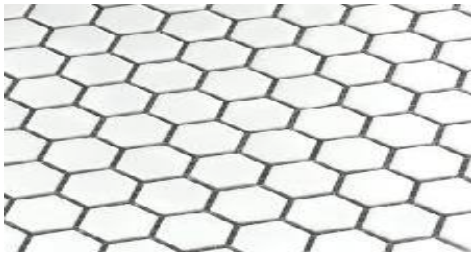

### 1.7.3 Flocculent Structure

This structure is characteristic of fine-grained soils such as clays. Inter-particle forces play a predominant role in the deposition. Mutual repulsion of the particles may be eliminated by means of an appropriate chemical; this will result in grains coming closer together to form a 'floc'. Formation of flocs is 'flocculation'. But the flocs tend to settle in a honeycomb structure, in which in place of each grain, a floc occurs. Thus, grains grouping around void spaces larger than the grain-size are flocs and flocs grouping around void spaces larger than even the flocs result in the formation of a 'flocculent' structure. Very fine particles or particles of colloidal size ( $< 0.001$  mm) may be in a flocculated or dispersed state. The flaky particles are oriented edge-to-edge or edge-to-face with respect to one another in the case of a flocculated structure. Flaky particles of clay minerals tend to form a card house structure (Lambe, 1953), when flocculated. When inter-particle repulsive forces are brought back into play either by remoulding or by the transportation process, a more parallel arrangement or reorientation of the particles occurs, as shown in Fig. This means more face-to-face contacts occur for the flaky particles when these are in a dispersed state. In practice, mixed structures occur, especially in typical marine soils.

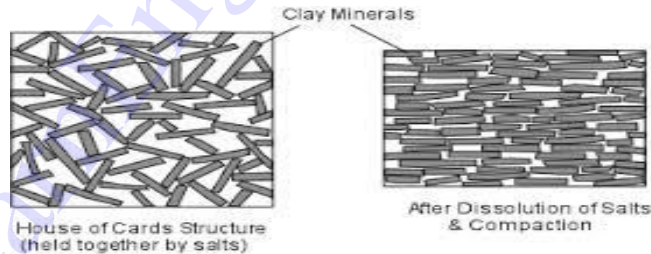
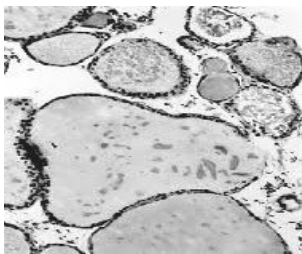

### 1.8 TEXTURE OF SOILS

The term 'Texture' refers to the appearance of the surface of a material, such as a fabric. It is used in a similar sense with regard to soils. Texture of a soil is reflected largely by the particle size, shape, and gradation. The concept of texture of a soil has found some use in the classification of soils to be dealt with later.

### 1.9 MAJOR SOIL DEPOSITS OF INDIA

The soil deposits of India can be broadly classified into the following five types:

1. **Black cotton soils**, occurring in Maharashtra, Gujarat, Madhya Pradesh, Karnataka, parts of Andhra Pradesh and Tamil Nadu. These are expansive in nature. On account of Fig. Flocculent structure flaky particles and Dispersed structure high swelling and shrinkage potential these are difficult soils to deal with in foundation design.
2. **Marine soils**, occurring in a narrow belt all along the coast, especially in the Rann of Kutch. These are very soft and sometimes contain organic matter, possess low strength and high compressibility.

**Desert soils**, occurring in Rajasthan. These are deposited by wind and are uniformly graded.

4. **Alluvial soils**, occurring in the Indo-Gangetic plain, north of the Vindhya ranges.

5. **Lateritic soils**, occurring in Kerala, South Maharashtra, Karnataka, Orissa and West Bengal.

### 1.9 Phases Relationship

The three constituents are blended together to form a complex material. It is also known as block diagram. Dry soil and saturated soil is known as two phase diagram.

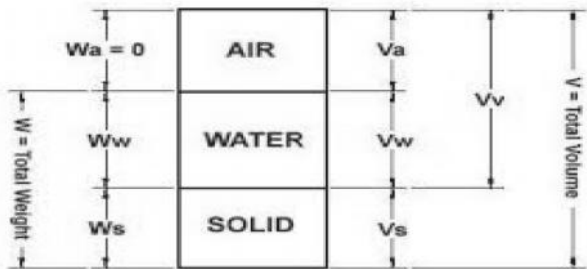

#### Weight

$$W_t = W_w + W_s + W_g$$

#### Volume

$$V_t = V_v + V_s = V_a + V_w + V_s + V_g$$

#### 1.9.1. Volumetric Relationships

##### i) Void ratio

It is defined as the ratio of volume of voids to the volume of solids.

$$e = V_v/V_s; \text{ the void ratio is expressed in decimal.}$$

##### ii) Porosity (n) or Percentage of voids

It is defined as the ratio of the volume of voids to the total volume.

$$n = V_v/V; \text{ Porosity is expressed as percentage \& it is not exceed 100\%.}$$

$$n = e/1+e; e = n/n-1$$

##### iii) Degree of Saturation (S)

The degree of saturation (s) is the ratio of the volume of water to the volume of voids.

$S = V_w/V_v$ ; The degree of saturation is generally as a percentage. It is equal to zero when the soil is absolutely dry & 100 % when the soil is fully saturated.

##### iv) Percentage of air voids (na)

It is defined as the ratio of the volume of air to the total volum,  $.na = V_a/V$  (it is represented as(%))

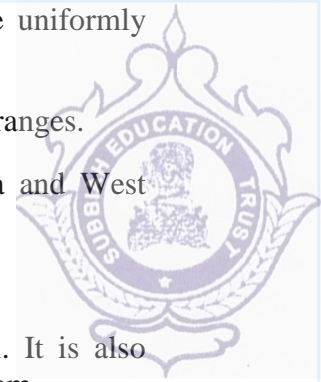



It is defined as the ratio of the volume of air to the volume of voids,  $ac = V_a/V_e$ ,

Air Content is usually expressed as percentage. Air Content and percentage of air voids are zero when the soil is saturated. ( $V_a=0$ )

$$n_a = V_a/V = V_a/V_v \cdot V_v/V$$

$$n_a = n \cdot ac$$

#### vi) Water content (w)

The water content (w) is defined as the ratio of the mass of water to mass of solids.

$w = M_w/M_s$ . It is also known as moisture content (m); it is expressed as percentage but used as a decimal computation.

### 1.9.2. Volume Mass Relationships

#### i) Bulk density ( $\rho$ )

The bulk mass density (  $\rho$  ) is defined as the total mass (m) per unit total volume (v)

$$\rho = m/v. \text{ It is also known as Bulk mass density, Bulk density, Wet mass density and density.}$$

It is expressed as  $kg/m^3$ ,  $gm/ml$  (or)  $mg/m^3$ .

#### ii) Dry mass density ( $\rho_d$ )

The dry density (  $\rho_d$  ) is defined as the mass of solids per unit total volume.

$$\rho_d = \frac{M_s}{V}$$

#### iii) Saturated density ( $\rho_{sat}$ )

The Saturated density is the bulk mass density of the soil when it is fully saturated.

$$\rho_{sat} = M_{sat}/V$$

#### iv) Submerged density

When the soil exists below water it is submerged conditions. When a volume of v of soil is submerged in water, it displaces an equal volume of water.

#### v) Density of solids

Density of solids is equal to the ratio of the mass of solids to the volume of solids.  $\rho_s = \frac{M_s}{V_s}$

### 1.9.3. Volume-Weight Relationships

#### i) Bulk unit weight ( $\gamma$ )

Bulk unit weight is defined as total weight per unit total volume.

$$\gamma = \frac{W}{V}. \text{ The bulk unit weight is also known as the total unit weight ( } \gamma_t \text{ ).}$$

It is expressed as  $N/m^3$  (or)  $KN/m^3$



It is defined as the weight of soil solids per unit total volume.  $d = \frac{W_s}{V}$

### iii) Saturated unit weight

The saturated unit weight is bulk unit weight when the soil is fully saturated. It is defined as weight of saturated soil solids to the unit total volume.

$$\gamma_{sat} = \frac{W_{sat}}{V}$$

### iv) Submerged unit weight ( ' )

It is defined as the submerged weight per unit of total volume.

$$= \frac{W_{sub}}{V}; \gamma = \gamma_{sat} - \gamma_w$$

### v) Unit weight of soil solids ( s )

The unit weight of solids ( s ) is equal to the ratio of the weight of solids to the total volume of solids.  $\gamma_s = W_s/V_s$

## 1.9.4 Specific gravity of solids (G)

i) **The specific gravity** of solid particles is defined as the ratio of the mass of a given volume of solids to the mass of an equal volume of water @ 4°C.  $G = \frac{\rho_s}{\rho_w}$

The specific gravity of solids for most natural soils is range of 2.65 to 2.80.

Here  $\rho_w = 1000 \frac{Kg}{m^3}$  (or)  $1 \frac{mg}{m^3}$ .

ii) **Mass specific gravity** (or) apparent specific gravity (or) Bulk specific gravity

It is defined as the ratio of the mass density of the soil to the mass density of water.

$$G_m = \frac{\rho}{\rho_w}$$

iii) **Absolute specific gravity (or) True specific gravity**

If all the internal voids of the particles are exclude from the determination the true volume of solids, then the specific gravity is called as Absolute (or) True specific gravity.

$$G_a = \frac{(\rho_s)_a}{\rho_w}$$

## 1.9.5. Density Index (ID)

Relative compactness of natural soil.

It is varies from 0 to 1

$$ID = \frac{e_{max} - e}{e_{max} - e_{min}}$$

e max = voids ratio in loosest state ; e min = voids ratio in densest state.

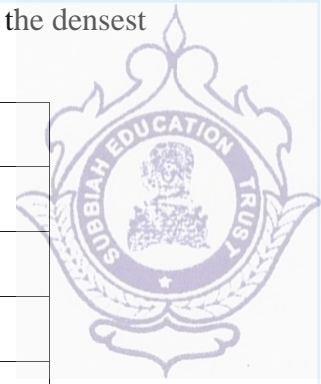

Relative Density	Density Description
0-15	Very loose
15-35	Loose
35-65	Medium
65-85	Dense
85-100	Very dense

### 1.9.6 Three phase diagram in terms of Void ratio

#### Mass

$$i) \quad = \frac{(G+S.e)\rho_w}{1+e}$$

$$ii) \quad d = \frac{G\rho_w}{1+e}$$

$$iii) \quad sat = \frac{(G+e)\rho_w}{1+e}$$

$$iv) \quad ' = \frac{(G-1)\rho_w}{1+e}$$

$$v) \quad , \frac{(G-1)-e(1-S).\rho_w}{1+e}$$

#### Unit weight

$$i) \quad = \frac{(G+Se)\gamma_w}{1+e}$$

$$ii) \quad \gamma_d = \frac{G.\gamma_w}{1+e}$$

$$iii) \quad \gamma_{sat} = \frac{(G+e).\gamma_w}{1+e}$$

$$iv) \quad , = \frac{(G-1).\gamma_w}{1+e}$$

$$v) \quad , = \frac{(G-1)-e(1-S).\gamma_w}{1+e}$$

### 1.9.7 Three phase diagram in terms of Porosity

#### Mass

$$i) \quad = (G(1-n) + Sn)\rho_w$$

$$ii) \quad d = G.\rho_w(1-n)$$

$$iii) \quad sat = (G(1-n) + n)\rho_w$$

$$iv) \quad ' = (G-1).(1-n)\rho_w$$

#### Unit weight

$$i) \quad \gamma = (G(1-n) + Sn).\gamma_w$$

$$ii) \quad d = G.\gamma_w(1-n)$$

$$iii) \quad sat = (G(1-n)+n).\gamma_w$$

$$iv) \quad ' = (G-1)(1-n).\gamma_w$$

### 1.9.8 Relationship between the void ratio and the water content

$$w = \frac{(S.e)}{G} \text{ (or) } e = \frac{w.G}{S}$$

For fully saturated soil  $S=1$ , i.e.  $w = \frac{e}{G}$ ;  $e = w.G$

### 1.9.9 Expression for mass density in terms of water content

#### Mass

$$i) \quad = \frac{(G+WG).\rho_w}{1+\frac{wG}{S}}$$

$$ii) \quad sat = \frac{(1+w)G\rho_w}{1+wG}$$

#### Unit weight

$$i) \quad \gamma = \frac{(1+w)G.\gamma_w}{1+\frac{wG}{S}}$$

$$ii) \quad \gamma_{sat} = \frac{(1+w)G.\gamma_w}{1+wG}$$

$$iii) \rho_{sub} = \frac{G \cdot \rho_w}{1 + wG}$$

$$iv) \rho_d = \frac{G \cdot \rho_w}{1 + \left(\frac{wG}{S}\right)}$$

$$v) \rho_d = \left(\frac{\rho}{1+w}\right)$$

$$vi) (\rho_d)_{sat} = \frac{G \cdot \rho_w}{1 + wG}$$

$$iii) \gamma_{sub} = \frac{(G-1)\gamma_w}{1+wG}$$

$$iv) \gamma_d = \frac{G \cdot \gamma_w}{1 + \left(\frac{wG}{S}\right)}$$

$$v) \gamma_d = \frac{\gamma}{1+w}$$

$$vi) \gamma_d(sat) = \frac{G \cdot \gamma_w}{1 + wG}$$



### 1.9.10 Relationship between Dry mass density and percentage

$$\rho_d = \frac{(1 - na)G \cdot \rho_w}{1 + wG} \quad (or) \quad \frac{(1 - na)(G \cdot \rho_w)}{1 + e}$$

$$\gamma_d = \frac{(1 - na)G \cdot \gamma_w}{1 + wG} \quad (or) \quad \frac{(1 - na)(G \cdot \gamma_w)}{1 + e}$$

### 1.10 Water content determination

Water content of soil sample can be determined by the following any one of the methods.

- i) Oven dry method
- ii) Torsion Balance method
- iii) Pyconometer method
- iv) Sand bath method
- v) Radiation method

#### 1.10.1 Specific gravity determination

The specific gravity of the particles is determined in the laboratory using the following methods

- i) Density bottle method
- ii) Pyconometer method
- iii) Shrinkage limit method

### 1.11 Soil Classification

#### Background and Basis of Classification:

The Geotechnical Engineers/Agencies had evolved many soil classification systems, over the world. The soil classification system developed by Casagrande was subsequently modified and named as 'Unified Classification' system. In 1959, Bureau of Indian Standards adopted the Unified classification system as a standard, which was revised in 1970. According to BIS classification system, soils are primarily classified based on dominant particle sizes and its plasticity characteristics. Soil particles mainly consist of following four size fractions.

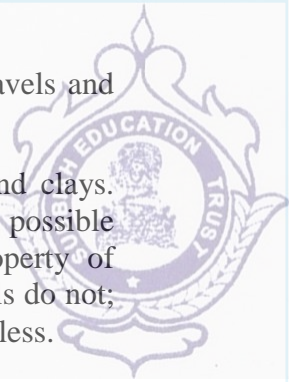

**1. Coarse-grained soils**, with average grain-size greater than 0.075 mm, *e.g.*, gravels and sands.

**2. Fine-grained soils**, with average grain-size less than 0.075 mm, *e.g.*, silts and clays. These exhibit different properties and behavior but certain general conclusions are possible even with this categorization. For example, fine-grained soils exhibit the property of 'cohesion'—bonding caused by inter-molecular attraction while coarse-grained soils do not; thus, the former may be said to be cohesive and the latter non-cohesive or cohesion less.

- Gravel : 80 – 4.75 mm
- Sand : 4.75mm – 0.075mm (75 micron)
- Silt : 75 – 2 micron
- Clay : less than 2 micron

Particle size distribution of a soil is determined by a combination of sieving and sedimentation analysis as per procedure detailed in IS: 2720 (Part 4) – 1985 and its plasticity characteristics are determined by Liquid Limit and Plastic Limit as per procedure detailed in IS:2720 (Part 5) –1985.

### 1.11.2 Symbols used in Soil Classification:

Symbols and other soil properties used for soil classification are given below. Brief procedure for Classification of soils has been explained in tabular form and Flow Chart. Plasticity Chart required for classification of fine grained soils has also been given.

#### Primary Letter

- G : Gravel
- S : Sand
- M : Silt
- C : Clay
- P: Peat

#### Secondary Letter

- W : well-graded
- P : poorly graded
- M : with non-plastic fines
- C : with plastic fines
- I : medium plasticity
- H : high plasticity

### 1.11.3 Other soil parameters required for soil classification:

$C_u$  : Coefficient of Uniformity =  $D_{60} / D_{10}$  .

$C_c$  : Coefficient of Curvature =  $(D_{30})^2 / (D_{60} * D_{10})$  .

$D_{60}$ ,  $D_{30}$  &  $D_{10}$  are particle sizes, below which 60,30 and 10 percent soil particles by weight are finer than these sizes.

Plasticity Index,  $PI = \text{Liquid Limit (LL)} - \text{Plastic Limit (PL)}$ .

Coarse-grained soils: Soils having fines ( particles of size less than 75 micron)  $< 50\%$ .

Fine grained soils: Soils having fines more than 50%.

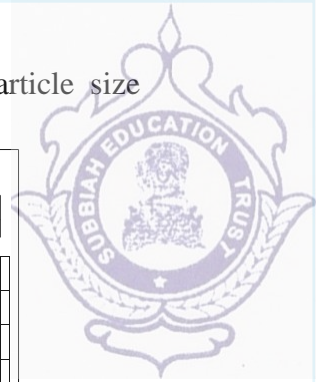

Conduct Sieve analysis and Hydrometer analysis on soil sample and plot particle size gradation curve and determine Cu and Cc.

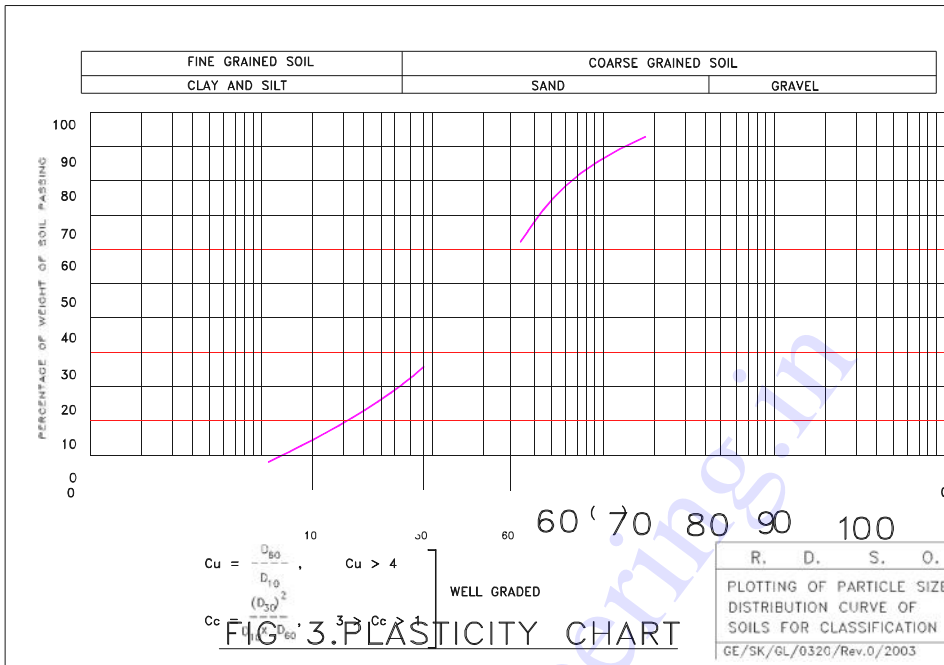

Conduct liquid limit and plastic limit test on soil samples as per procedure given fig

Based on above soil parameters, classification should be done as per procedure explained in the following table/Flow Chart. The classification should be done in conjunction with the Plasticity Chart given below.

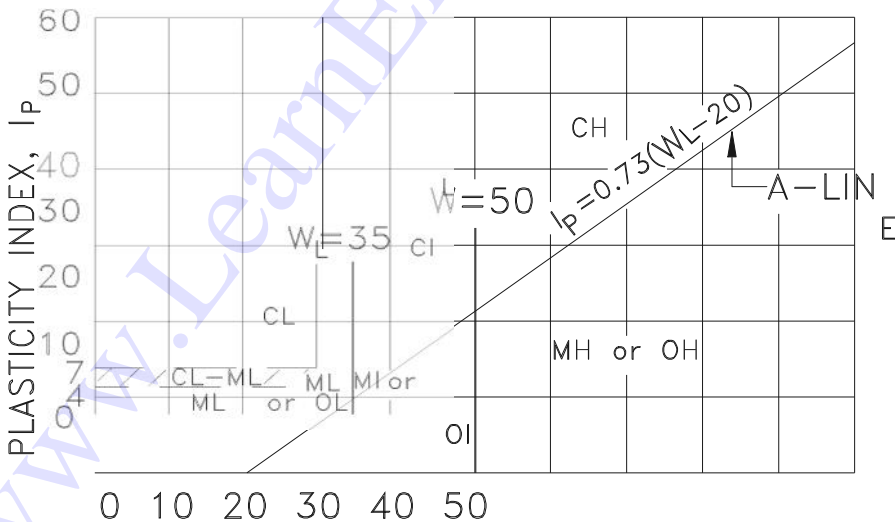

**Broad categorization of soil type**

The classified soil types shall be grouped in four broad categories for the purpose of planning of works (Blanket thickness requirement as indicated in bracket is for new constructions. Planning for rehabilitation, if any, is to be done in consultation with RDSO.)

a) Soils type A (not needing blanket):

Rocky beds except those, which are very susceptible to weathering e.g. rocks consisting of shales and other soft rocks, which become muddy after coming into contact with water.

Well graded Sand (SW)

Soils conforming to specifications of blanket material.

b) Soils type B (needing 45cm thick blanket):

Poorly graded Gravel (GP) having Uniformity Coefficient more than 2.

Poorly grade Sand (SP) having Uniformity Coefficient more than 2.

Silty Gravel (GM)

Silty Gravel – Clayey Gravel (GM – GC).

c) Soils type C (needing 60cm thick blanket):

Clayey Gravel (GC)

Silty Sand (SM)

Clayey Sand (SC)

Clayey Silty sand (SM-SC)

Note: The thickness of blanket on above type of soils shall be increased to 1m, if the plasticity index exceeds 7.

d) Soils type D (needing 1m thick blanket):

Silt with low plasticity (ML)

Silty clay of low plasticity (ML-CL)

Clay of low plasticity (CL)

Silt of medium plasticity (MI)

Clay of medium plasticity (CI)

Rocks which are very susceptible to weathering

Soils having fines passing 75 micron sieve between 5 & 12%, i.e. for soils with dual symbol e.g., GP-GC, SW-SM, etc., thickness of blanket should be provided as per soil of second symbol (of dual symbol)

### 1.12 Sampling tools:

i) Crow bar and pickaxe along with khurpi etc.

ii) Hand carved sampler, chunk sampling



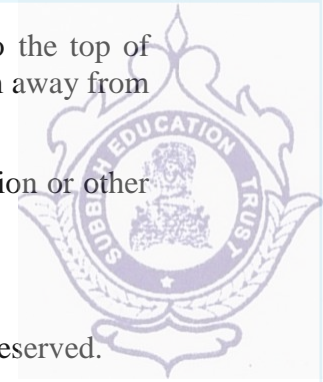

i) Ballast shall be removed up to the bottom of ballast penetration, and/or upto the top of subgrade i.e., just below the blanket level. (160 cm from CL of track or 20-30 cm away from the edge of the sleeper)

ii) Disturbed /undisturbed soil sample (min 2.0 kg) shall be collected by excavation or other means.

iii) The excavation pit shall be at least 100 mm below the bottom of ballast.

iv) Collected soil sample shall be kept in a poly bag with seal, so that, fines are preserved.

v) A slip of location (km/chainage), section, divisions alongwith name of zonal railway shall be placed in the poly bag.

vi) The excavated pit shall be refilled with local material and be well compacted.

### Testing:

Only two types of tests shall be performed on each sample.

a) Atterberg limit tests (Liquid Limit and plastic limit).

b) Grain size analysis (Mechanical sieving).

**Atterberg limit tests: IS: 2720 pt V 1985.**

### a) Equipment:

i) Mechanical /LL apparatus

ii) Grooving tool, Casagrande, ASTM

iii) Procelain evaporating dish, 12 to 15cm dia

iv) Spatula

v) Balance (Physical or electronic)

vi) Oven

vii) Wash Bottle

viii) Air tight container, IS Sieve 4254 of a 600 mm x 600mm glass sheet, ix) A soil sample weighing about 120 g

### b) Procedure:

#### i) Liquid limit:

- Air dry the soil sample remove the organic matter like tree roots, pieces of bark etc.
- About 270gm of air dried pulverized soil which is already sieved through 425 micron, IS Sieve is taken.
- Water is added with air dried soil to make a paste and ensure uniform distribution of moisture throughout the soil mass. Clayey soil left to stand for 24 hours.
- A standard groove is made in the soil paste by the grooving tool suitable for the type of soil.

➤ The cup is made to fall freely through a height of 1cm by turning e ram at the rate of two revolutions per second.

- The no. of drops required closing, the groove by about 12mm in the central portion is noted.
- Determine moisture content of representative slice of soil from the groove and including the soil flowed.
- With increasing water content, the number of drops required to close the groove shall not be more than 35 or less than 15. Determine the moisture content in each case.
- A graph is plotted on semi log paper, with no. of drops on log scale as abscissa and moisture content on natural log scale as ordinate.
- The water content at 25 drops is read from the graph. It is the liquid limit (LL) for the soil sample. Generally these points lie on a straight line.

## ii) Plastic limit:

- After doing liquid limit test, the leftover soil paste is worked with a spatula on glass sheet to drive away a part of moisture content to make it plastic enough to be shaped into a ball.
- A small mass of the plastic mass is taken of rolled on a glass sheet by pressure of the palm into a solid thread 3mm dia until it crumbles.
- These rolls are collected of put into oven for drying for moisture for each test.
- The average content is reported as plastic limit.

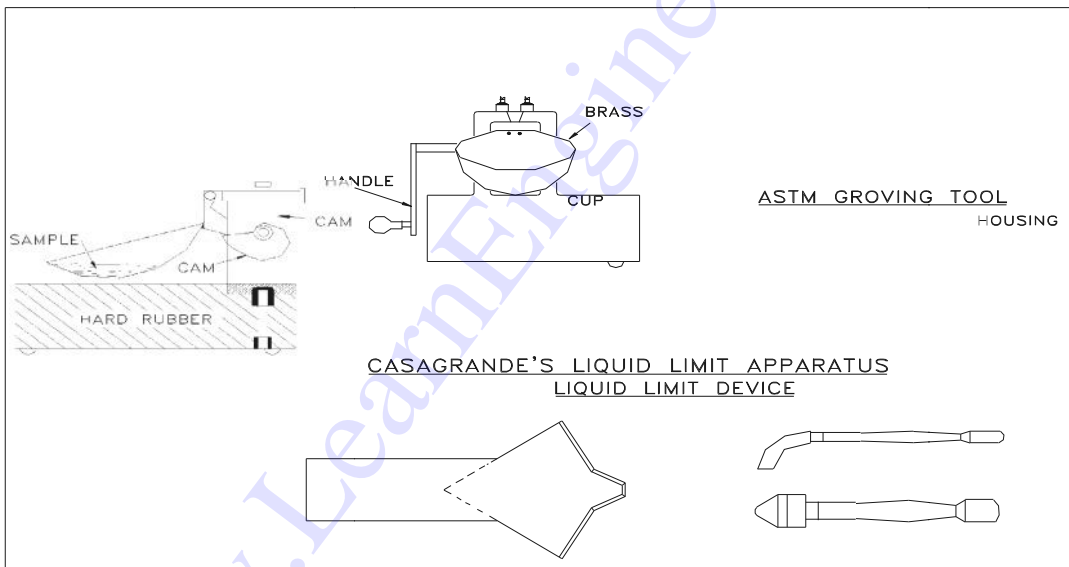

## 1.13 Index properties

### 1.13.1 Particle Size Distribution

First of all, let's discuss the sieve that is the essential tool to study particle size distribution.

U.S. Standard Sieve Sizes

Sieve	Sieve opening (mm)
4	4.75
10	2.00
20	0.850
40	0.425
60	0.250
100	0.150
200	0.074



### 1.13.2 Gradation:

Gradation is a measure of the distribution of a particular soil sample. Larger gradation means a wider particle size distribution. Well graded  $\bar{U}$  poorly sorted (e.g., glacial till) Poorly graded  $\bar{U}$  well sorted (e.g., beach sand)

The range of grain size distribution is enormous for natural soils. E.g., boulder can be  $\sim 1$  m in diameter, and the colloidal mineral can be as small as  $0.00001$  mm =  $0.01$  micron. It has a tremendous range of 8 orders of magnitude.

**Example:** If you have a soil sample with a weight of 150 g, after thorough sieving you get the following result.

sieve	size(mm)	W(g)	%	accum%	100accum%
4	4.750	30.0	20	20	80
20	0.850	40.0	26.7	46.7	53.3
60	0.250	50.0	33.3	79	21
100	0.150	20.0	13.3	92	8
200	0.074	10.0	6.67	98	2

The last column shows the percentage of material finer than that particular sieve size by weight.

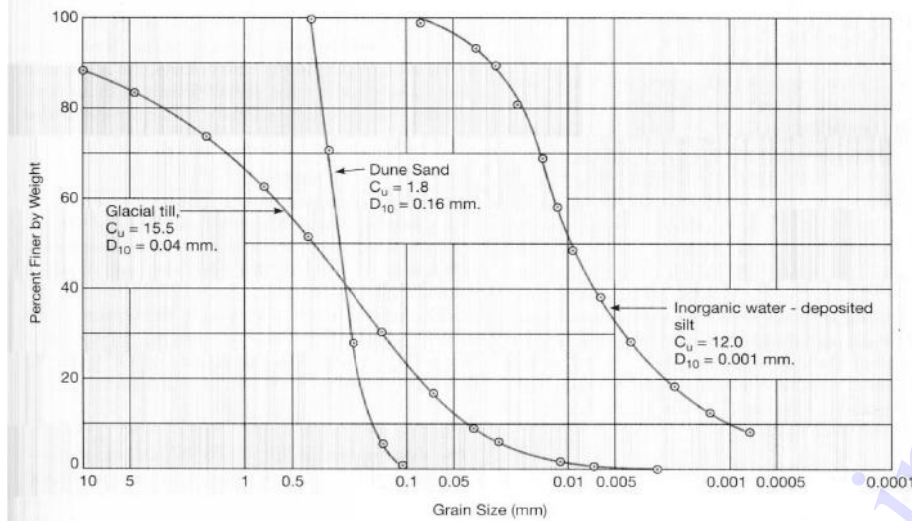

There are a number of ways to characterize the particle size distribution of a particular soil sample. **D<sub>10</sub>**:

D<sub>10</sub> represents a grain diameter for which 10% of the sample will be finer than it. Using another word, 10% of the sample by weight is smaller than diameter D<sub>10</sub>. It is also called the effective size and can be used to estimate the permeability.

Hazen's approximation (an empirical relation between hydraulic conductivity with grain size)  $k \text{ (cm/sec)} = 100D_{10}^2$

Where D<sub>10</sub> is in centimeters.

It is empirical because it is not consistent in dimension (cm/sec vs cm<sup>2</sup>).

### Uniformity coefficient **C<sub>u</sub>**:

$$C_u = D_{60}/D_{10}$$

Where D<sub>60</sub> is the diameter for which 60% of the sample is finer than D<sub>60</sub>.

The ratio of two characteristic sizes is the uniformity coefficient **C<sub>u</sub>**. Apparently, larger **C<sub>u</sub>** means the size distribution is wider and vice versa. **C<sub>u</sub> = 1** means uniform, all grains are in the same size, such as the case of dune sands. On the other extreme is the glacial till, for which its **C<sub>u</sub>** can reach 30.

from  $C_u = D_{60}/D_{10}$ , then  $D_{60} = C_u D_{10}$

### Coefficient of Curvature **C<sub>c</sub>**

Another shape parameter, as the second moment of grain size distribution curve, is called the coefficient of curvature, and defined as

$$C_c = (D_{30}^2) / (D_{10} D_{60})$$

A soil is thought to be well graded if the coefficient of curvature **C<sub>c</sub>** between 1 and 3, with **C<sub>u</sub>** greater than 4 for gravels and 6 for sands.

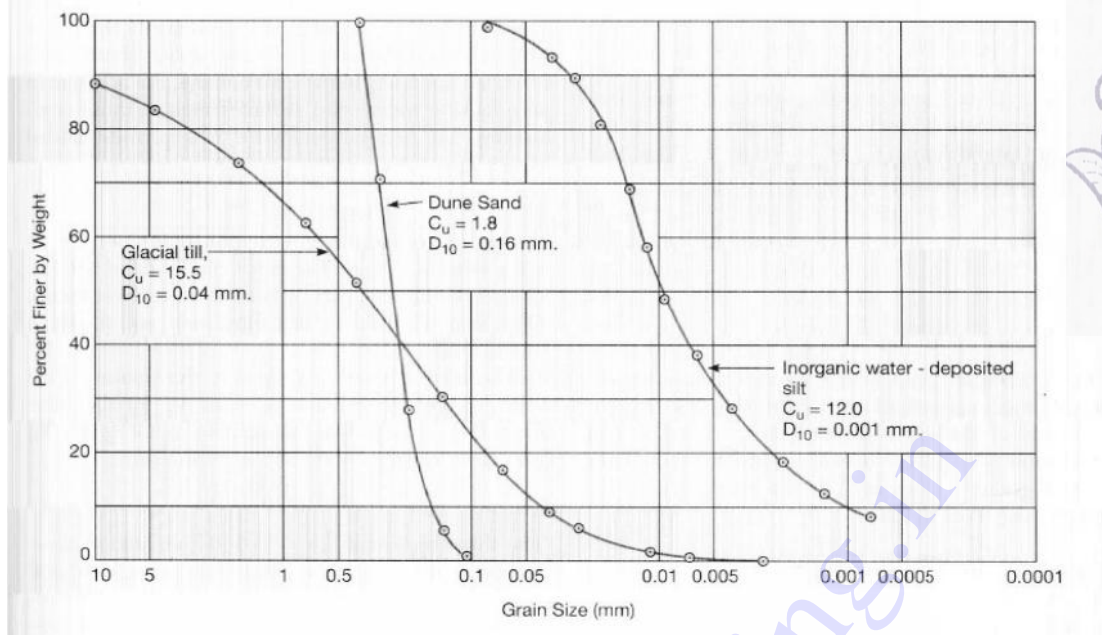

Problem 7.1: Grain Size Distribution

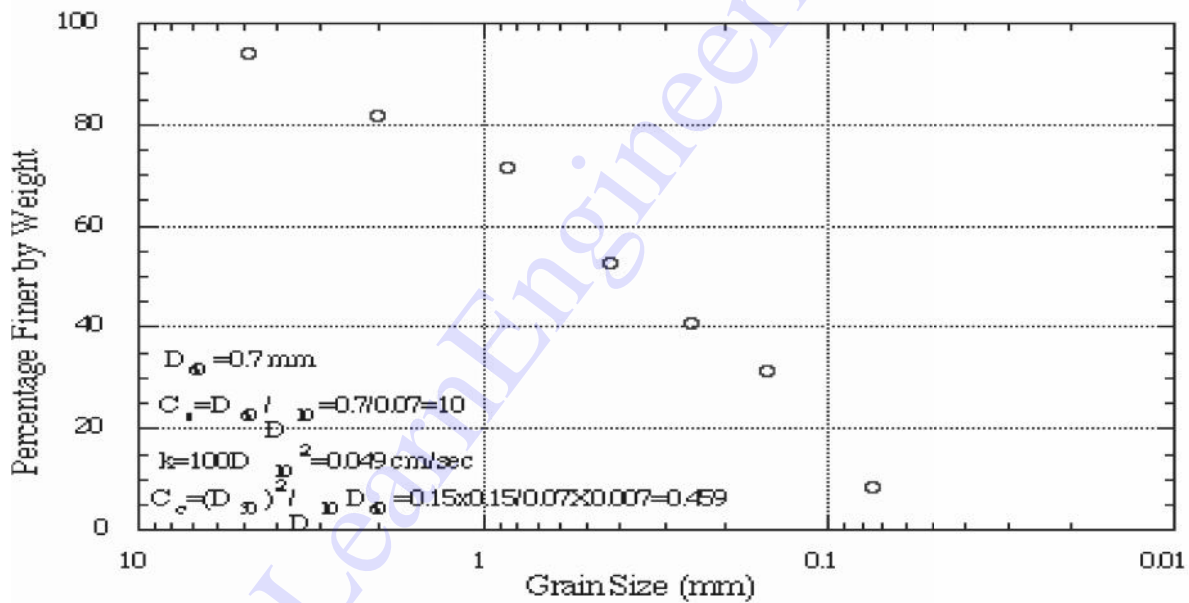

### 1.14 Engineering Properties

- i) Permeability
- ii) Compressibility
- iii) Shear strength

#### 1.14.1 Permeability

It indicates the facility with which water can flow through soils. It is required for estimation of seepage discharge through earth masses.

### 1.14.2 Compressibility

It is related with the deformations produced in soils when they are subjected to compressive load.

### 1.14.3 Shear Strength

It determines the stability of slope bearing capacity of soils and the earth pressure on retaining structures.

### 1.15 Compaction

In construction of highway embankments, earth dams and many other engineering structures, loose soils must be compacted to improve their strength by increasing their unit weight; Compaction - Densification of soil by removing air voids using mechanical equipment; the degree of compaction is measured in terms of its dry unit weight.

#### 1.15.1 Objectives for Compaction

- Increasing the bearing capacity of foundations;
- Decreasing the undesirable settlement of structures;
- Control undesirable volume changes;
- Reduction in hydraulic conductivity;
- Increasing the stability of slopes.

**In general, soil densification includes compaction and consolidation.**

**Compaction** is one kind of densification that is realized by rearrangement of soil particles without outflow of water. It is realized by application of mechanic energy. It does not involve fluid flow, but with moisture changing altering.

**Consolidation** is another kind of densification with fluid flow away. Consolidation is primarily for clayey soils. Water is squeezed out from its pores under load.

CONSOLIDATION	COMPACTION
It is a gradual process of reduction of Volume under sustained, static loading.	It is a rapid of reduction of volume mechanical mean such as rolling , tamping , vibration.
It causes a reduction in volume of a saturated soil due to squeezing out of water from the soil.	In compaction, the volume of partially saturated soil decreases of air the voids at the unaltered water content
Is a process which in nature when saturated soil deposits are subjected to static loads caused by the weight of the building	Is an artificial process which is done to increase the density of the soil to improve its properties before it is put to any use.

### 1.15.2 Compaction Effect

There are 4 control factors affecting the extent of compaction:

- Compaction effort;
- Soil type and gradation;
- Moisture content; and
- Dry unit weight (dry density).

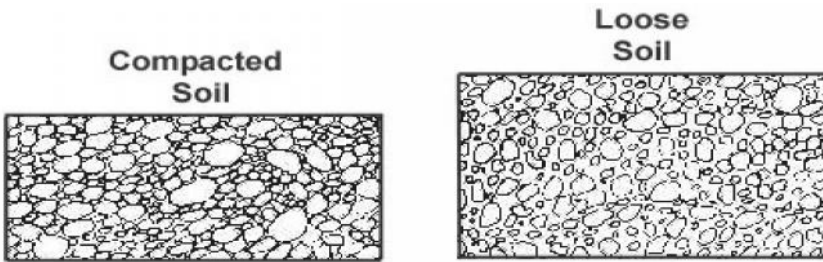

### 1.15.3 Effect of Water on Compaction

In soils, compaction is a function of water content

Water added to the soil during compaction acts as a softening agent on the soil particles

- Consider 0% moisture - Only compact so much
- Add a little water - compacts better
- A little more water - a little better compaction
- Even more water – Soil begins to flow

#### What is better compaction?

The dry unit weight ( $\gamma_d$ ) increases as the moisture content increases **to a point**

Beyond a certain moisture content, any increase in moisture content tends to reduce the dry unit weight

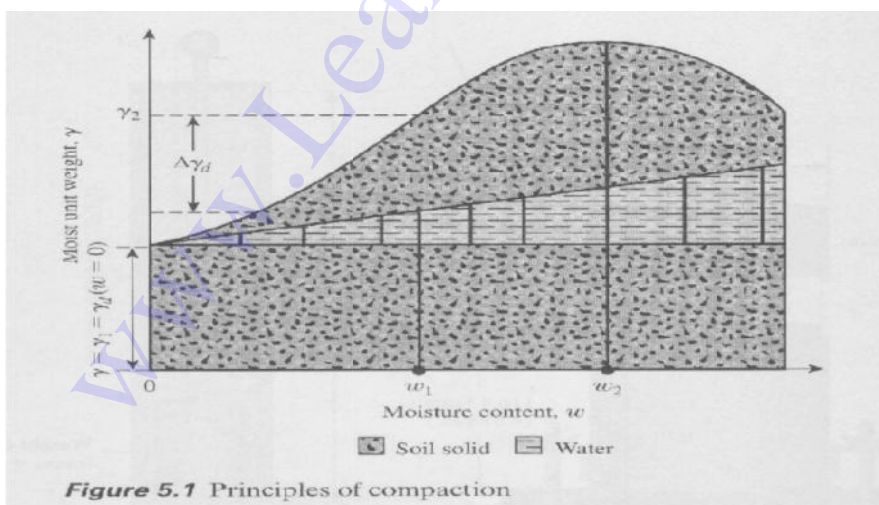

**Das, Figure 5.1**

### 1.15.4 Standard Proctor Compaction Test

The standard was originally developed to simulate field compaction in the lab

#### Purpose:

Find the optimum moisture content at which the maximum dry unit weight is attained

ASTM D 698

#### Equipments;

Standard Proctor; 1/30 ft<sup>3</sup> mold

5.5 lb hammer; 12" drop

3 layers of soil; 25 blows / layer

#### Compaction Effort is calculated with the following parameters

- Mold volume = 1/30 cubic foot
- Compact in 3 layers
- 25 blows/layer
- 5.5 lb hammer
- 12" drop

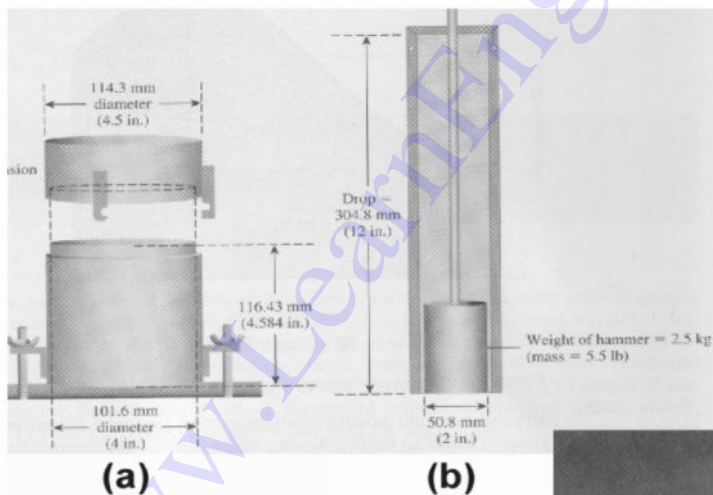
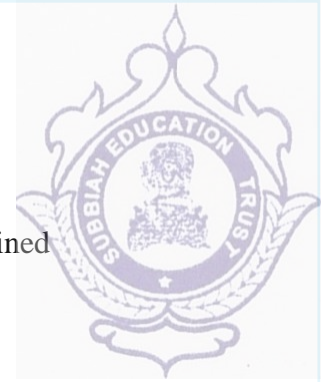

Das. Figure 5.2

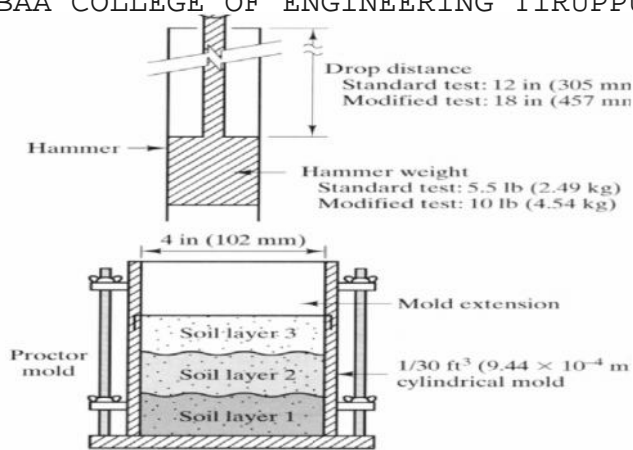

## Compaction Lab Equipment

### Procedure

1. Obtain 10 lbs of soil passing No. 4 sieve
2. Record the weight of the Proctor mold without the base and the (collar) extension, the volume of which is  $1/30 \text{ ft}^3$ .
3. Assemble the compaction apparatus.
4. Place the soil in the mold in 3 layers and compact using 25 well distributed blows of the Proctor hammer.
5. Detach the collar without disturbing the soil inside the mold
6. Remove the base and determine the weight of the mold and compacted soil.
7. Remove the compacted soil from the mold and take a sample (20-30 grams) of soil and find the moisture content
8. Place the remainder of the molded soil into the pan, break it down, and thoroughly remix it with the other soil, plus 100 additional grams of water.

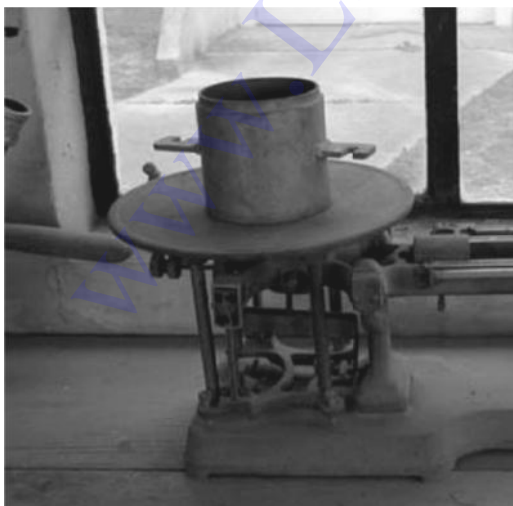

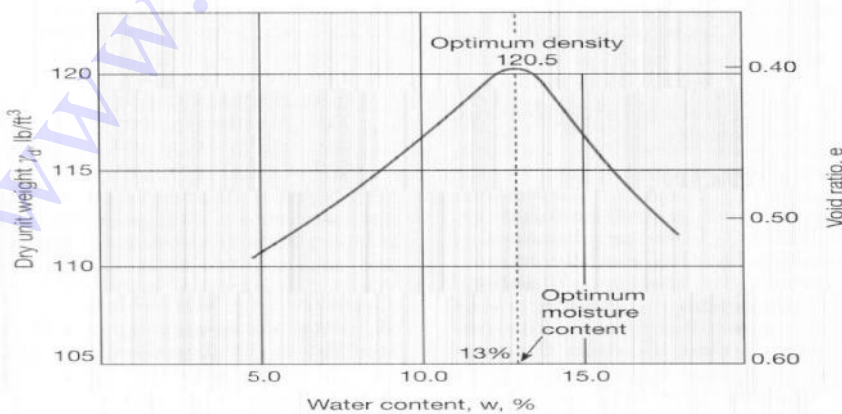
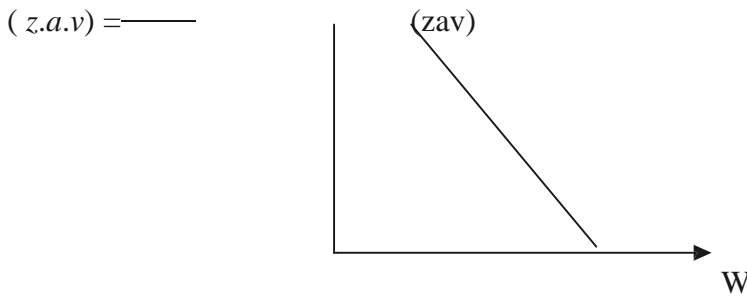

FIGURE 7.16 Standard Proctor compaction Curve.

**Zero-air-void unit weight:**



At certain water content, what is the unit weight to let no air in the voids



It is clear that in the above equation, specific gravity of the solid and the water density are constant, the zero-air-void density is inversely proportional to water content  $w$ . For a given soil and water content the best possible compaction is represented by the zero-air-voids curve. The actual compaction curve will always be below. For dry soils the unit weight increases as water is added to the soil because the water lubricates the particles making compaction easier. As more water is added and the water content is larger than the optimum value, the void spaces become filled with water so further compaction is not possible because water is a kind like incompressible fluid. This is illustrated by the shape of the zero-air-voids curve which decreases as water content increases.

**Compaction Curve**

Compaction curve plotted  $\gamma_d$  vs.  $w$ . The peak of the curve is the Maximum Compaction ( $\gamma_{dmax}$ ) at Optimum Moisture Content ( $w_{opt}$ )

**Results**

Plot of dry unit weight vs moisture content

Find  $\gamma_d$  (max) and  $w$  and Plot Zero-Air-Void unit weight (only  $S=100\%$ )

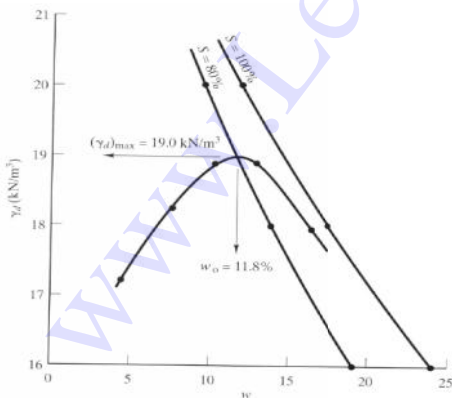



**Example 5.1**

The laboratory test data for a standard Proctor test are shown below. Find the maximum dry unit weight and optimum moisture content.

Moisture content (%)	Weight of wet soil and mould (N)	Moisture content (%)
10	3.200	12
12	3.400	14
14	4.200	16
16	4.250	18
18	4.200	20
20	4.100	22

**Solution**

The following table can now be prepared:

Moisture content (%)	Weight of wet soil and mould (N)	Moisture content (%)	Dry unit weight (kN/m <sup>3</sup> )
10	3.200	12	113.50
12	3.400	14	117.20
14	4.200	16	120.00
16	4.250	18	120.20
18	4.200	20	119.00
20	4.100	22	117.00

The graph of  $\gamma_d$  against  $w$  is shown in Figure 5.1.2. From the graph maximum dry unit weight = 120.2 kN/m<sup>3</sup> Optimum moisture content = 16.3%.

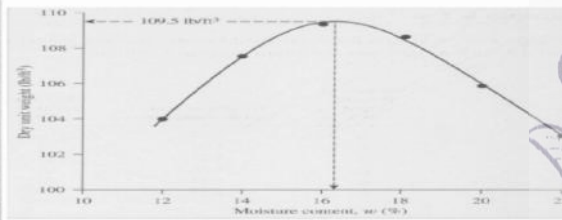

### 1.15.5 Effect of Compaction Energy

With the development of heavy rollers and their uses in field compaction, the Standard Proctor Test was modified to better represent field compaction

#### As the compaction effort increases,

The maximum dry unit weight of compaction increase; the optimum moisture content decreases to some extent Compaction energy per unit volume.

### 1.15.6 Compaction adopted in the field

#### i) Tampers.

A hand operated tamper consists of block iron, about 3 to 5 Kg mass, attached to a wooden rod. The tamper is lifted for about 0.30m and dropped on the soil to be compressed. Mechanical Tampers operated by compressed air or gasoline power.

#### ii) Rollers

- a) smooth – wheel rollers
- b) pneumatic – tyred rollers
- c) Sheep- foot rollers.

#### a) Smooth – wheel rollers

Smooth – wheel rollers are useful finishing operations after compaction of fillers and for compacting granular base causes of highways.

#### b) Pnumatic – tyred rollers

Pneumatic – tyred rollers use compressed air to develop the required inflation pressure. The roller compactive the soil primarily by kneading action. These rollesrs are effecting for compacting cohesive as well as cohesion less soils.

#### c) Sheep – foot rollers

The sheep – foot roller consists of a hollow drum with a large number of small projections (known as feet) on its surface. The drums are mounted on a steel frame. The drum can fill with water or ballast increases the mass. The contact pressure is generally between 700 to 4200 KN/m<sup>2</sup>.



- A soil sample has a porosity of 40% .the specific gravity of solids 2.70,  
 Calculate (a) void ratio  
 (b) Dry density  
 (c) Unit weight if the soil is 50% saturated  
 (d) Unit weight if the soil is completely saturated

Solution:

$$(a) e = \frac{n}{1-n} = \frac{0.4}{1-0.4} = 0.667$$

$$(b) \gamma_d = \frac{G \cdot \gamma_w}{1+e} = \frac{2.7 \cdot 9.81}{1+0.667} = 15.89 \text{ KN / m}^3$$

$$(c) e = \frac{w \cdot G}{S_r}$$

$$w = \frac{e S_r}{G} = \frac{.667 \cdot 0.5}{2.7} = 0.124$$

$$\gamma = \gamma_d (1+w) = 15.89 \cdot 1.124 = 17.85 \text{ KN / m}^3$$

- (d) When the soil is fully saturated

$$e = w_{sat} \cdot G$$

$$w_{sat} = e / G = 0.667 / 2.7 = 0.247$$

$$\gamma_{sat} = G \gamma_w (1-n) + \gamma_w \cdot n$$

$$= 2.7 \cdot 9.81(1-0.4) + 9.81 \cdot 0.4 = 19.81 \text{ KN / m}^3$$

An undisturbed sample of soil has a volume of 100 cm<sup>3</sup> and mass of 190.g. On oven drying for 24 hrs, the mass is reduced to 160 g. If the specific gravity grain is 2.68, determine the water content, voids ratio and degree of saturation of the soil.

Solution:

$$M_w = 190 - 160 = 30 \text{ g}$$

$$M_d = 160 \text{ g}$$



$$W = M_w / M_d = 30 / 160 = 0.188 = 18.8 \%$$

$$\text{Mass of moist soil} = M = 190 \text{ g}$$

$$\text{Bulk density} = M / V = 190 / 100 = 1.9 \text{ g/cm}^3$$

$$\gamma = 9.81 * \rho = 9.81 * 1.9 = 18.64 \text{ KN/m}^3$$

$$\begin{aligned} \gamma_d &= \frac{\gamma}{1+w} \\ &= \frac{18.64}{1+0.188} = 15.69 \text{ KN/m}^3 \end{aligned}$$

$$\begin{aligned} e &= \frac{G\gamma_w}{\gamma_d} - 1 \\ \frac{2.68 * 9.81}{15.69} - 1 &= 0.67 \end{aligned}$$

$$S_r = \frac{wG}{e} = \frac{0.188 * 2.68}{0.67} = 0.744 = 74.45\%$$

**Prove that :**

$$n_a = \frac{e(1-S_r)}{1+e}$$

$$n_a = \frac{V_v}{V}$$

$$V_a = V_v - V_w = e - e_w$$

$$V = V_s + V_v = 1+e$$

$$n_a = \frac{e - e_w}{1+e}$$

$$e_w = e S_r \quad \text{from equ} \quad \rightarrow (1)$$

$$n_a = e - e S_r / (1+e) = e(1 - S_r) / (1+e)$$

$$n_a = e(1 - S_r) / (1+e) \quad \rightarrow (4)$$

Soil water – static pressure in water - Effective stress concepts in soils – capillary stress – Permeability measurement in the laboratory and field pumping in pumping out tests – factors influencing permeability of soils – Seepage – introduction to flow nets – Simple problems. (Sheet pile and weir).

## 2.1 INTRODUCTION

All soils are permeable materials, water being free to flow through the interconnected pores between the solid particles. The pressure of the pore water is measured relative to atmospheric pressure and the level at which the pressure is atmospheric (i.e. zero) is defined as the water table (WT) or the phreatic surface. Below the water table the soil is assumed to be fully saturated, although it is likely that, due to the presence of small volumes of entrapped air, the degree of saturation will be marginally below 100%.

## 2.2 SOIL WATER

Water presence in the voids of soil mass is called soil water. It can be classified in several ways:

### 2.2.1 Broad classification:

1. Free water
  2. Held water
- a. Structural water b. Adsorbed water c. Capillary water

### 2.2.2 Classification on phenomenological basis

1. Ground water
2. Capillary water
3. Adsorbed water
4. Infiltrated water

### 2.2.3 Classification on structural aspect

1. Pore water
2. Solvate water
3. Adsorbed water
4. Structural water

#### Free water

Water is free to move through a soil mass under the influence of gravity.

#### Held water

It is the part of water held in the soil pores by some force existing within the pores.

Such water is not free to move under gravitational force.

Adsorbed water is that water which the soil particles freely adsorb from atmosphere by physical force of attraction and held by force of adhesion.

Water in the vicinity of soil particles subjected to an attractive force basically consists of two components.

- i) Attraction of bipolar water to be electrical charged soil.
- ii) Attraction of dipolar water to the action in the double layer, cation in turn attract to the particles.

### **Structural water**

It is the water chemically combined in the crystal structure of the soil mineral. Structural water cannot be separated or removed and also not removed by oven drying at 105-110°C. It can be destroyed at higher temperature which will destroy the crystal structure.

### **Infiltrated water**

Infiltrated water is the portion of surface precipitation which soaks into ground, moving downwards through air containing zones.

### **Pore water**

It is capable of moving under hydrodynamic forces unless restricted in its free movement such as when entrapped between air bubbles or retention by capillary forces.

Gravitational and capillary water are the two types of pore water.

### **Solvate water**

The water which forms a hydration shell around soil grains is solvate water. It is subjected to polar electrostatic and binding forces.

### **Ground water**

Subsurface water that fills the voids continuously and is subjected to no force other than gravity is known as gravitational water.

## **2.3 Capillary water**

The minute pores of soil serve as capillary tubes through which the moisture rises above the ground water table.

Capillary water is the soil moisture located within the interstices and voids of capillary size of the soil.

Capillary water is held in the interstices of soil due to capillary forces. Capillary action or capillarity is the phenomenon of movement of water in the interstices of a soil due to capillary forces.

The capillary forces depend upon various factors such as surface tension of water, pressure in water in relation to atmospheric pressure, and the size and conformation of soil pores.

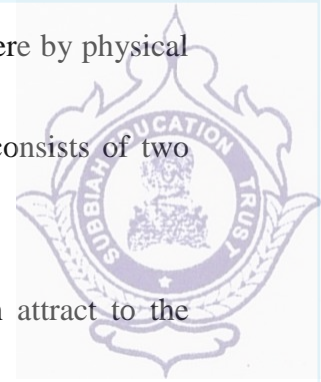

Water can also be held by surface tension round the point of contact of two particles (spheres) capillary water in this form is known as contact moisture (or) contact capillary water.

### 2.3.2 CAPILLARY RISE

The pores of soil mass may be looked upon as a series of capillary tubes, extending vertically above water table.

The rise of water in the capillary tubes, or the fine pores of the soil, is due to the existence of surface tension which pulls the water up against the gravitational force.

The height of capillary rise, above the ground water (or free water) surface depends upon the diameter of the capillary tube (or fineness of the pores) and the value of the surface tension.

When a capillary tube is inserted in water, the rise of water will take place up to reach the equilibrium. At this stage the rise of water in the tube is stopped. At this equilibrium position, when the height of rise is  $h_c$ , the weight of column of water is equal to  $\left(\frac{\pi d^2}{4}\right)(\rho_w h_c)$

The weight of water in the tubes is supported by the surface tension of meniscus circumference in the tube.

$$h_c = \frac{T_s \cos \alpha}{\gamma_w d}$$

### 2.3.3 INFLUENCE OF CLAY MINERALS

Soil undergoes a volume change when the water content cause shrinkage while increase of water content swelling.

Large volume changed in clayey soils lead to structural damage. For clayey soils, the degree of change in volume depends upon factors such as

- i) Type and amount of clay minerals present in the soil.
- ii) Specific surface area of clay.
- iii) Structure of soil.
- iv) Pore water salt concentration.

The two fundamental building blocks for clay minerals are

- i) Silica tetrahedral unit
- ii) Gibbsite

#### i) Silica tetrahedral unit

Four oxygen or hydroxyls having a configuration of tetrahedral enclose silicon. It is resembled in the symbol representing the oxygen based layer and hydroxyl apex layer.

#### ii) Gibbsite

Aluminum, iron or magnesium atom is enclosed in six hydroxyls.

Surface tension of water is the property which exists in the surface film of water tending to contract the contained volume into a form having minimum superficial area possible

$$T_s = 72.8 \left( \frac{\text{dynes}}{\text{cm}} \right) \text{ or } 0.728 \times 10^{-6} \left( \frac{\text{KN}}{\text{cm}} \right) \text{ at } 20^\circ\text{C}$$

The surface tension of water is double the surface tension of other liquids.

### Capillary tension (or) capillary potential

Tensile stress caused in water is called the capillary tension or capillary potential. It is also called as pressure deficiency or pressure reduction or negative pressure.

$$u_c = \gamma_w h_c \quad u_c \text{ max} = \gamma_w (h_c) \text{ max}$$

### 2.3.4 SOIL SUCTION

The tensile stress in the meniscus circumferences caused in water is called the capillary tension or the capillary potential. The capillary tension or capillary potential is the pressure deficiency, pressure reduction or negative pressure in the pore water (or the pressure below atmospheric) by which water is retained in a soil mass. It decreases linearly from a maximum value of  $h_c$  at the level of the meniscus to zero value at the free water surface.

The pressure deficiency in the held water is also termed as soil suction or suction pressure.

Soil suction is measured by the height  $h_c$  in centimeters to which a water column could be drawn by suction in a soil mass free from external stress.

The common logarithm of this height (cm) or pressure (g/cm<sup>2</sup>) is known as the pF value (Schofield, 1935):  $pF = \log_{10}(h_c)$

Thus, a pF value of 2 represents a soil suction of 100 cm of water or suction pressure and capillarity of 100 g/cm<sup>2</sup>.

#### Factors affecting soil suction:

1. Particle size of soil
2. Water content
3. Plasticity index of soil mass
4. Soil structure
5. History of wetting and drying
6. Soil density
7. Temperature
8. Angle of contact
9. Dissolved salts in water



JA The magnitude of the pressure is the same as the height above the free water surface. The capillary pressure transferred from grain to grain called as inter angular or effective pressure.

**2.4.1 Capillary action (or) capillarity:**

It is the phenomenon of movement of water in the interstices of a soil due to capillary forces. The capillary forces depend upon various factors such as surface tension of water, pressure in water in relation to atmospheric pressure and the size and conformation of soil pores.

**2.4.2 Contact moisture.**

Water can also be held by surface tension round the point of contact of two particles (spheres) capillary water in this form is known as contact moisture (or) contact capillary water.

**2.5 EFFECTIVE STRESS CONCEPTS IN SOIL**

At any plane in a soil mass, the total stress or unit pressure  $\sigma$  is the total load per unit area.

This pressure may be due to i) self weight of soil ii) over burden on the soil.

The total pressure consists of two distinct components: inter granular pressure or effective pressure and the neutral pressure or pore pressure. Effective pressure  $\sigma'$  is the pressure transmitted from particle through their point of contact through the soil mass above the plane.

Such a pressure, also termed as inter granular pressure, is effective in decreasing the voids ratio of the soil mass and in mobilizing its shear strength. The neutral pressure or the pore water pressure or pore pressure is the pressure transmitted through the pore fluid.

Therefore, this pressure is also called neutral pressure (u). Since the total vertical pressure at any plane is equal to the sum of the effective pressure and pore water pressure we have,

$$\sigma = \sigma' + u$$

**2.5.1 Submerged soil mass:**

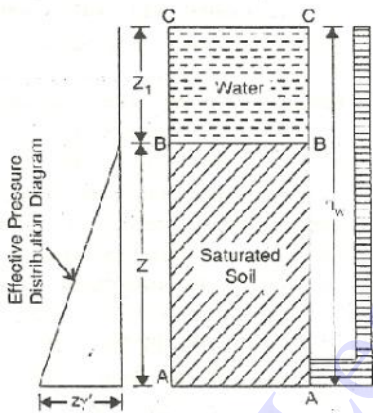

**2.5.2 Soil mass with surcharge:**

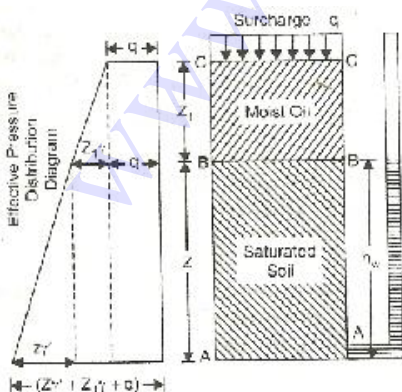



Generally bulking of sand increases as the particle size of sand decreases. This is because of the increase in the specific surface area of the sand. Upon further subsequent increase in moisture content in sand, when a maximum increase in bulking volume is attained, bulking in its turn decreases, and upon the inundation of the sand the surface tension forces are neutralized, and most of the bulking, in such a case vanishes. As a consequence, the sand particles now rearrange themselves into a denser packing.

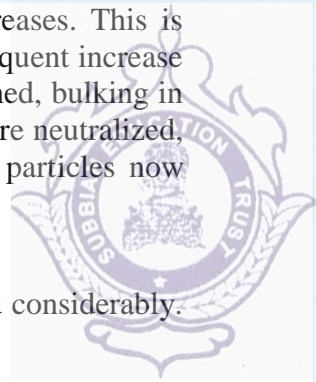

### Effect of bulking on sand

Bulking of sand in a loose state of packing decreases the bearing capacity of sand considerably. In compacting sandy soils, low densities are usually achieved because of bulking.

## 2.6 PERMEABILITY:

Permeability is defined as the property of a porous material which permits the passage or seepage of water (or other fluids) through its interconnecting voids. A material having continuous voids is called permeable. Gravels are highly permeable while stiff clay is the least permeable and hence such clay may be termed impermeable for all practical purposes.

The flow of water through soils may either be a laminar flow or a turbulent flow. In laminar flow, each fluid particle travels along a definite path which never crosses the path of any other particle. In turbulent flow, the paths are irregular and twisting, crossing and recrossing at random (Taylor, 1948).

In most of the practical flow problems in soil mechanics, the flow is laminar. The study of seepage of water through soil is important for the following engineering problems :

1. Determination of rate of settlement of a saturated compressible soil layer.
2. Calculation of seepage through the body of earth dams, and stability of slopes.
3. Calculation of uplift pressure under hydraulic structures and their safety against piping.
4. Ground water flow towards wells and drainage of soil.

### 2.6.1 Coefficient of permeability (or) permeability.

It is defined as the average velocity of flow that will occur through the total cross-sectional area of soil under unit hydraulic gradient. The coefficient of permeability is denoted as K. It is usually expressed as cm/sec (or) m/day (or) feet/day.

#### Darcy's Law:

When the flow is laminar in a saturated soil, the rate of flow or discharge per unit time is proportional to the hydraulic gradient.

$$q = k i a.$$

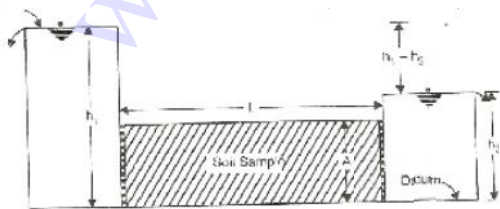

$$q = \text{discharge per unit time} \quad v = \frac{q}{A} = k i$$

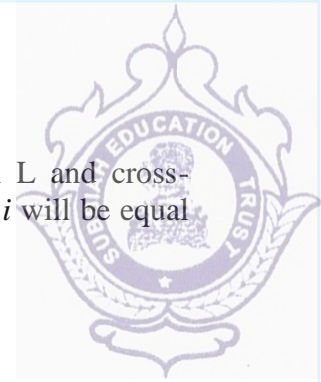

k = Darcy's coefficient of permeability

v = velocity of flow, or average discharge velocity. If a soil sample of length L and cross-sectional area A, is subjected to differential head of water, the hydraulic gradient i will be equal to

$$q = \frac{h_1 - h_2}{L} \cdot (A)$$

### 2.6.2 Factors affecting permeability:

1. Grain size
2. Properties of the pore fluid
3. Voids ratio of the soil
4. Structural arrangement of the soil particles
5. Entrapped air and foreign-matter
6. Adsorbed water in clayey soils.

### 2.6.3 The coefficient of permeability can be determined by the following methods:

#### (a) Laboratory methods

- (1) Constant head permeability test.
- (2) Falling head permeability test.

#### (b) Field methods

- (1) Pumping-out tests.
- (2) Pumping-in tests.

#### (c) Indirect methods

- (1) Computation from grain size or specific surface.
- (2) Horizontal capillarity test
- (3) Consolidation test data.

### 2.6.4 Constant head permeability test

The coefficient of permeability of a soil sample determined by the constant water pressure. The test is conducted with a fixed water level. Permeability is measured in cm/sec.

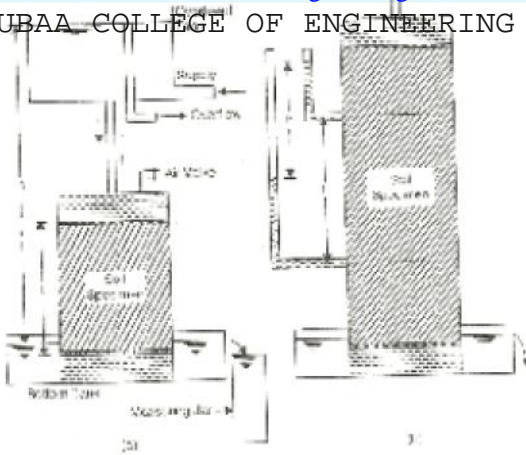

Co efficient of permeability by constant head method

$$k = \frac{QL}{Aht} = \frac{qL}{Ah}$$

Constant head permeability most used for coarse grained soils.

### 2.6.5 Falling head permeability test

A Stand pipe of known cross sectional area is fitted over the permeameter and water is allowed to run down. The water level in the stand pipe constantly falls as water flows.

The head of water on the stand pipe at time intervals is observed and the data used to determine the coefficient of permeability.

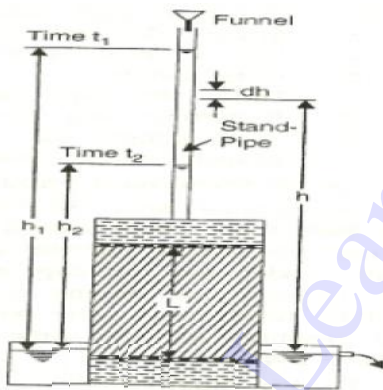

$$k = \frac{(2.303)(qL)}{At} \log_{10} \left( \frac{h_1}{h_2} \right)$$

Falling head permeability test relatively used for less permeable soils.

## 2.7 SEEPAGE

When water flows through a saturated soil mass, the total head at any point in the soil mass consists of (i) piezometric head or pressure head, (ii) the velocity head, and (iii) the position head. The below shown figure represents the flow of water through a saturated soil sample, of length L, due to the difference in elevation of free water surface at A and B.

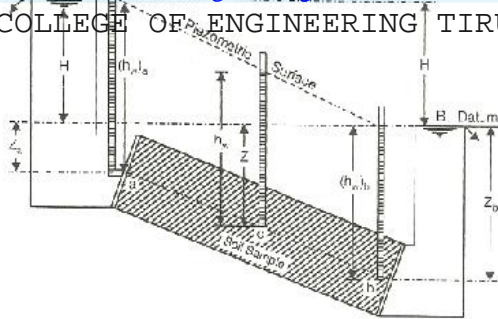

At the upper point a of the soil specimen, piezometric head is  $(h_w)_a$  - At the lower point b, the piezometric head is  $(h_w)_b$  - At any intermediate point c, the piezometric head  $h_w$  is equal to the height through which the water rises in a piezometric tube inserted at that point.

The piezometric head is also called the pressure head. A piezometric surface is the line joining the water levels in the piezometers. The vertical distance between the piezometric levels at point 'a' and 'b' is called the initial hydraulic head  $H$  under which the flow takes place. The position or elevation head at any point is the elevation of that point with respect to any arbitrary datum. The position head  $Z$  is taken positive if it is situated above the datum and negative if below the datum.

A symbol  $\phi$  is sometimes used in place of  $h$  to represent the hydraulic potential or the potential function. However, when  $\phi$  represents a product of  $k$  and  $h$ , it is known as the velocity potential. The loss of head or the dissipation of the hydraulic head per unit distance of flow through the soil is called the hydraulic gradient  $i = h/L$ . By virtue of the viscous friction exerted on water flowing through soil pores, an energy transfer is effected between the water and the soil. The force corresponding to this energy transfer is called the **seepage force or seepage pressure**. Thus, seepage pressure is the pressure exerted by water on the soil through which it percolates. It is this seepage pressure that is responsible for the phenomenon known as quick sand and is of vital importance in the stability analysis of earth structures subjected to the action of seepage.

### 2.7.1 Importance for the study of seepage of water

- Determination of rate of settlement of a saturated compressible soil layer.
- Calculation of seepage through the body of earth dams, and stability of slopes.
- Calculation of uplift pressure under hydraulic structure and their safety against piping.
- Ground water flow towards well and drainage of soil

### 2.7.2 Quick Sand Condition:

When flow takes place in an upward direction, the seepage pressure also acts in the upward direction and the effective pressure is reduced. If the seepage pressure becomes equal to the pressure due to submerged weight of the soil, the effective pressure is reduced to zero. In such a case, cohesion less soil loses all its shear strength, and the soil particles have a tendency to move up in the direction of flow. This phenomenon of lifting of soil particles is called quick condition, boiling condition or quick sand. The hydraulic gradient at such a critical state is called the critical hydraulic gradient.

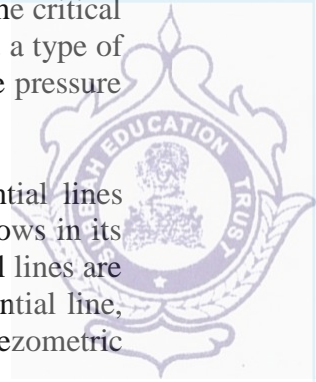

For loose deposits of sand or silt, if voids ratio  $e$  is taken as 0.67 and  $G$  as 2.67, the critical hydraulic gradient works out to be unity. It should be noted that quick sand is not a type of sand but a flow condition occurring within a cohesion less soil when its effective pressure is reduced to zero due to upward flow of water.

**2.8 FLOW NET**

A flow net for an isometric medium is a network of flow lines and equipotential lines intersecting at right angles to each other. The path which a particle of water follows in its course of seepage through a saturated soil mass is called a flow line. Equipotential lines are lines that intersect the flow lines at right angles. At all points along an equipotential line, the water would rise in piezometric tubes to the same elevation known as the piezometric head .

**2.8.1 LAPLACE EQUATION:**

Laplace equation for two dimensional flows.

Assumption

1. The saturated porous medium is compressible. The size of the pore space doesn't change with time, regardless of water pressure.
2. The seeping water flows under a hydraulic gradient which is due only to gravity head loss, or Darcy's law for flow through porous medium is valid.
3. There is no change in the degree of saturation in the zone of soil through which water seeps and quantity of water flowing into any element of volume is equal to the quantity which flows out in the same length of time.
4. The hydraulic boundary conditions of any entry and exit are known
5. Water is incompressible. Consider an element of soil of size  $x, y$  and of unit thickness perpendicular to the plane of the paper Let  $V_x$  and  $V_y$  be the entry velocity components in X and Y directions.

Then  $(Vs) + \left(\frac{\partial V_x}{\partial x}\right) \cdot x$  and  $(Vy) + \left(\frac{\partial V_y}{\partial y}\right) \cdot y$

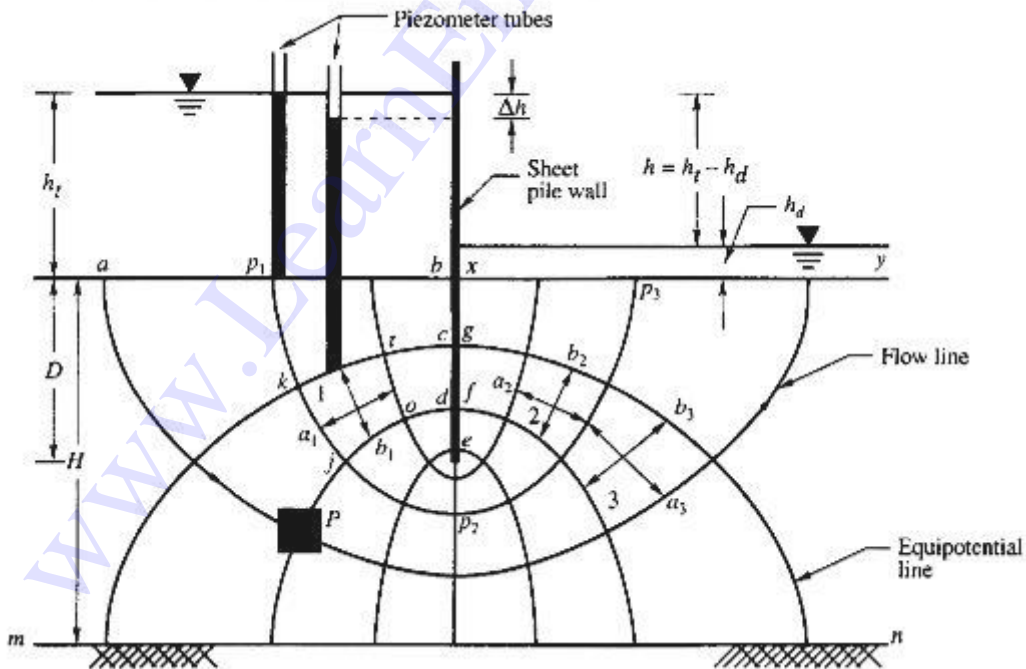

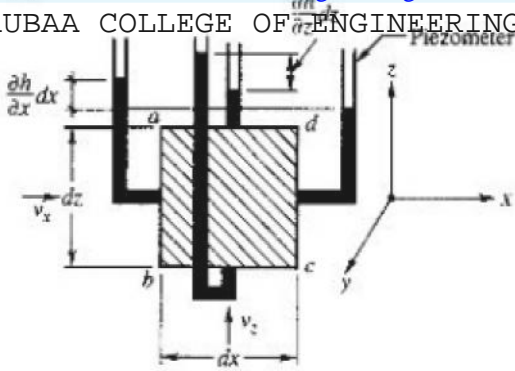

The figure represents a section through an impermeable diaphragm extending to a depth below the horizontal surface of a homogeneous stratum of soil of depth  $H$ . It is assumed that the difference  $h$  between the water levels on the two sides of the diaphragm is constant. The water enters the soil on the upstream side of the diaphragm, flows in a downward direction and rises on the downstream side towards the surface. Consider a prismatic element  $P$  shown shaded in Fig.2.8 which is shown on a larger scale in 2.9. The element is a parallelepiped with sides'  $dx$ ,  $dy$  and  $dz$ . The  $x$  and  $z$  directions are as shown in the figure and the  $y$  direction is normal to the section. The velocity  $v$  of water which is tangential to the stream line can be resolved into components  $v_x$  and  $v_z$  in the  $x$  and  $z$  directions respectively.

$i_x = -(\partial h)/(\partial x)$  the hydraulic gradient in the horizontal direction.

$i_z = -(\partial h)/(\partial z)$  the hydraulic gradient in the vertical direction.

$k_x$  = hydraulic conductivity in the horizontal direction.

$k_z$  = hydraulic conductivity in the vertical direction.

If we assume that the water and soil are perfectly incompressible, and the flow is steady, then

the quantity of water that enters the element must be equal to the quantity that leaves it.

The quantity of water that enters the side  $ab = v_x dz dy$

The quantity of water that leaves the side  $cd = v_x + (\partial v_x / \partial x) dx dy dz$

The quantity of water that enters the side  $bc = v_z dx dy$

The quantity of water that leaves the side  $ad = v_z + (\partial v_z / \partial z) dz dx dy$

Therefore, we have the equation,

$$V_x dz dy + V_z dx dy = (V_x + \left(\frac{\partial V_x}{\partial x}\right) dx) dy dz + (V_z + \left(\frac{\partial V_z}{\partial z}\right) dz) dx dy$$

$$\frac{\partial V_x}{\partial x} + \frac{\partial V_z}{\partial z} = 0 \quad V_x = - (k_x) \left(\frac{\partial h}{\partial x}\right) \quad V_z = - (k_z) \left(\frac{\partial h}{\partial z}\right)$$

$$k_x \frac{\partial^2 h}{\partial x^2} + k_z \frac{\partial^2 h}{\partial z^2} = 0$$

If the soil is homogeneous  $k_x = k_z$ , then the laplace equation,

$$\frac{\partial^2 h}{\partial x^2} + \frac{\partial^2 h}{\partial z^2} = 0$$

### 2.8.2 Flow net Construction:

The graphical method of flow net construction, first given by Forchheimer (1930), is

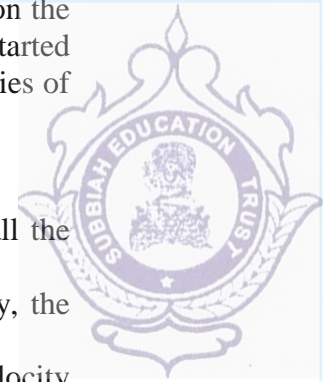

based on trial sketching. The hydraulic boundary conditions have a great effect on the general shape of the flow net, and hence must be examined before sketching is started. The flow net can be plotted by trial and error by observing the following properties of flow net and by following the practical suggestions given by A. Casagrande.

**2.8.3 Properties of flow net.**

The flow lines and equipotential lines meet at right angles to one another. The fields are approximately squares, so that a circle can be drawn touching all the four sides of the square. The quantity of water flowing through each flow channel is the same. Similarly, the same potential drop occur between two successive equipotential lines. Smaller the dimensions of the field, greater will be the hydraulic gradient and velocity of flow through it.

In a homogeneous soil, every transition in the shape of the curves is smooth, being either elliptical or parabolic in shape.

**2.8.4 Hints to draw flow net:**

Use every opportunity to study the appearance of well constructed flow nets. When the picture is sufficiently absorbed in your mind, try to draw the same flow net without looking at the available solution ; repeat this until you are able to sketch this flow net in a satisfactory manner. Four or five flow channels are usually sufficient for the first attempts ; the use of too many flow channels may distract the attention from essential features. Always watch the appearance of the entire flow net. Do not try to adjust details before the entire flow net is approximately correct. The beginner usually makes the mistake of drawing too sharp transitions between straight and curved sections of flow lines or equipotential lines. Keep in mind that all transitions are smooth, of elliptical or parabolic shape. The size of the squares in each channel will change gradually.

**2.8.5 FLOW NET FOR VARIOUS WATER RETAINING STRUCTURES**

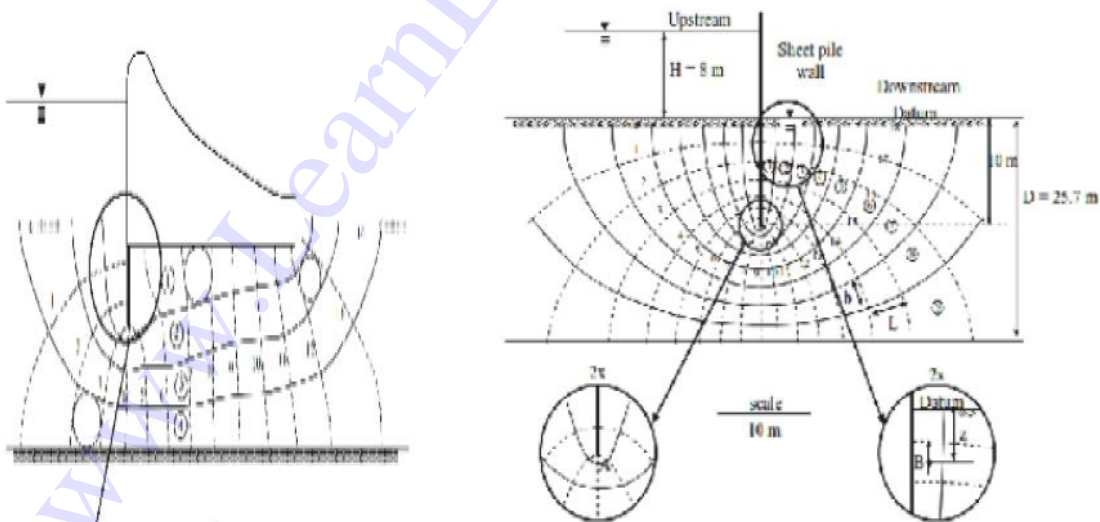

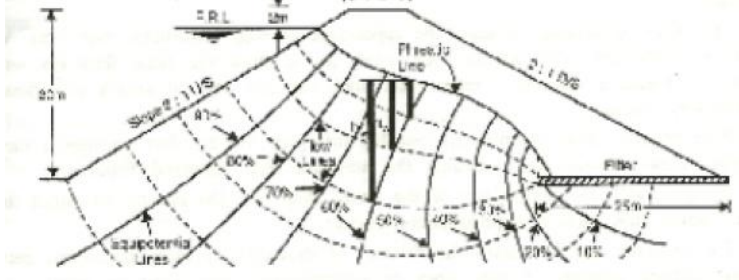

**2.8.6 Flow net can be utilized for the following purposes:**

- Determination of seepage,
- Determination of hydrostatic pressure,
- Determination of seepage pressure,
- Determination of exit gradient

**i. Determination of seepage**

The portion between any two successive flow lines is at flow channel. The portion enclosed two successive equipotential lines and successive flow lines are known as field.

Let  $b$  and  $l$  be the width and length of the field.

$h$  = head drop through the field

$q$  = discharge passing through the flow channel

$H$  = Total hydraulic head causing flow = difference between upstream and downstream weeds.

**ii. Determination of hydrostatic pressure.**

The hydrostatic pressure at any point within the soil mass is given by  $u = h w$

Where,  $u$  = hydrostatic pressure

$hw$  = Piezometric head.

The hydrostatic pressure in terms of piezometric head  $hw$  is calculated from the following relation.

$$h w = h - z$$

**iii. Determination of seepage pressure**

The hydraulic potential  $h$  at any point located after  $N$  potential drops, each of value  $h'$  is given by  $b H = \epsilon_i h'$

The seepage pressure of any point the hydraulic potential or the balance hydraulic head multiplied by the unit

Weight of water,  $Ps h\gamma_w . Hh$

The pressure acts in the direction flow

**iv. Determination of exit gradient.**

The exit gradient is the hydraulic gradient of the downstream end of the flow line where the percolating water leaves the soil mass and emerges into free water at the downstream. The exit gradient can be calculated from the following expression, in which  $\Delta h$  represents the potential drop and  $l$  the average length of last field in the flow net all the exit end.

$$ie = \frac{\Delta h}{L}$$

For a depth of 12m the soil consists of very fine sand having an average voids ratio of 0.7. Above the water table the sand has an average degree of saturation of 50%. Calculate the effective pressure on a horizontal plane at a depth 10 meters below the ground surface. What will be the increase in the effective pressure if the soil gets saturated by capillarity up to a height of 1m above the water table? Assume  $G = 2.65$

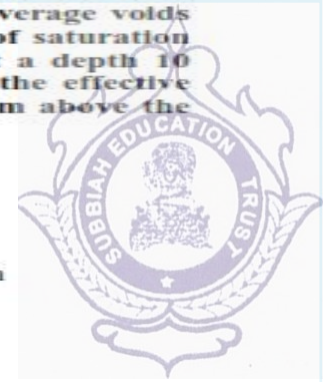

**Solution:**

$$\text{Height of sand layer above water table} = Z_1 = 4 \text{ m}$$

$$\text{Height of saturated layer above water table} = 12 - 4 = 8 \text{ m}$$

$$\text{Depth of point X, where pressure is to be computed} = 10 \text{ m}$$

$$\text{Height of saturated layer above X} = Z_2 = 10 - 4 = 6 \text{ m}$$

Now

$$\gamma_d = \frac{G\gamma_w}{1+e} = \frac{2.65 \times 9.81}{1+0.7} = 15.29 \text{ KN/m}^3$$

i. For sand above water table:-

$$e = \frac{\omega G}{S_r}$$

$$\omega = \frac{e S_r}{G} = \frac{0.7 \times 0.5}{2.65} = 0.132$$

$$\gamma_1 = \gamma_d(1 + \omega) = 15.29 \times 1.132 = 17.31 \text{ KN/m}^3$$

ii. For saturated sand below water table

$$\omega_{sat} = \frac{e}{G} = \frac{0.7}{2.65} = 0.264$$

$$\gamma_2 = \gamma_d(1 + \omega_{sat})$$

$$15.29(1 + 0.264)$$

$$\gamma_2 = 19.33 \text{ KN/m}^3$$

$$\gamma_2^1 = 19.33 - 9.81 = 9.52 \text{ KN/m}^3$$

Effective pressure at X

$$\sigma = Z_1 \gamma_1 + Z_2 \gamma_2$$

$$\sigma = 4 \times 17.31 + 6 \times 19.33$$

$$= 185.22 \text{ KN/m}^2$$

$$u = h_w \gamma_w = 6 \times 9.81 = 58.86 \text{ KN/m}^2$$

$$\sigma^1 = \sigma - u = 185.22 - 58.86 = 126.36 \text{ KN/m}^2$$

Effective stress at x after capillary rise

$$\sigma^1 = 3\gamma_1 + (6+1)\gamma_2^1 + h_c \gamma_w$$

$$= (3 \times 17.31) + (7 \times 9.52) + (1 \times 9.81)$$

$$= 128.38 \text{ KN/m}^2$$

Increase in pressure

$$= 128.38 - 126.36 = 2.02 \text{ KN/m}^2$$

**Result:**

i. Effective pressure at a depth of 10m = 128.38 KN/m<sup>2</sup>

ii. Increase in pressure = 2.02 KN/m<sup>2</sup>

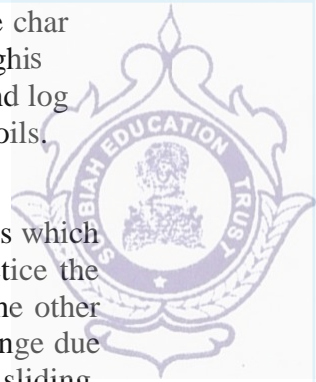

### 3.1 INTRODUCTION

A soil can be visualized as a skeleton of solid particles enclosing continuous voids which contain water and/or air. For the range of stresses usually encountered in practice the individual solid particles and water can be considered incompressible; air, on the other hand, is highly compressible. The volume of the soil skeleton as a whole can change due to rearrangement of the soil particles into new positions, mainly by rolling and sliding, with a corresponding change in the forces acting between particles. The actual compressibility of the soil skeleton will depend on the structural arrangement of the solid particles. In a fully saturated soil, since water is considered to be incompressible, a reduction in volume is possible only if some of the water can escape from the voids. In a dry or a partially saturated soil a reduction in volume is always possible due to compression of the air in the voids, provided there is scope for particle rearrangement. Shear stress can be resisted only by the skeleton of solid particles, by means of forces developed at the interparticle contacts. Normal stress may be resisted by the soil skeleton through an increase in the interparticle forces. If the soil is fully saturated, the water filling the voids can also withstand normal stress by an increase in pressure.

#### 3.1.1 THE PRINCIPLE OF EFFECTIVE STRESS

The importance of the forces transmitted through the soil skeleton from particle to particle was recognized in 1923 when Terzaghi presented the principle of effective stress, an intuitive relationship based on experimental data. The principle applies only to fully saturated soils and relates the following three stresses:

1. The total normal stress ( $\sigma$ ) on a plane within the soil mass, being the force per unit area transmitted in a normal direction across the plane, imagining the soil to be a solid (single-phase) material;
2. the pore water pressure ( $u$ ), being the pressure of the water filling the void space between the solid particles;
3. the effective normal stress ( $\sigma'$ ) on the plane, representing the stress transmitted through the soil skeleton only.

The relationship is:

The principle can be represented by the following physical model. Consider a 'plane XX in a fully saturated soil, passing through points of interparticle contact only, as shown in Figure. The wavy plane XX is really indistinguishable from a true plane on the mass scale due to the relatively small size of individual soil particles. A normal force  $P$  applied over an area  $A$  may be resisted partly by interparticle forces and partly by the pressure in the pore water. The interparticle forces are very random in both magnitude and direction throughout the soil mass but at every point of contact on the wavy plane may be split into components normal and tangential to the direction of the true plane to which XX approximates; the normal and tangential components are  $N'$  and  $T$ , respectively. Then, the effective normal stress is interpreted as the sum of all the components  $N'$  within the area  $A$ , divided by the area  $A$ , i.e.

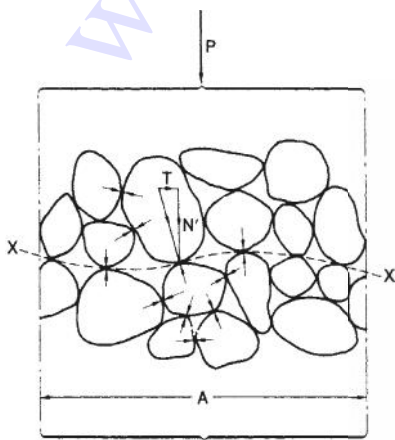

The total normal stress is given by —

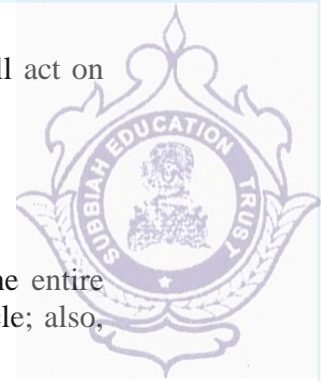

If point contact is assumed between the particles, the pore water pressure will act on the plane over the entire area  $A$ .

Then, for equilibrium in the direction normal to  $XX$

$$p = \epsilon N' + uA \quad \text{or} \quad \left(\frac{p}{A}\right) = \frac{\epsilon N'}{A}$$

ie  $\sigma = \sigma + u$

The pore water pressure which acts equally in every direction will act on the entire surface of any Particle but is assumed not to change the volume of the particle; also, the pore water pressure does not

cause particles to be pressed together. The error involved in assuming point contact between particles is negligible in soils, the total contact area normally being between 1 and 3% of the cross-sectional area  $A$ . It should be understood that  $N'$  does not represent the true contact stress between two particles, which would be the random but very much higher stress  $N'$ , where  $a$  is the actual contact area between the particles.

### 3.1.2 Effective vertical stress due to self-weight of soil

Consider a soil mass having a horizontal surface and with the water table at surface level. The total vertical stress (i.e. the total normal stress on a horizontal plane) at depth  $z$  is equal to the weight of all material (solids & water) per unit area above that

$$\sigma_v = \gamma_{sat} z$$

The pore water pressure at any depth will be hydrostatic since the void space between the solid particles is continuous, so at depth  $z$   $u = \gamma_w z$  Hence, from Equation is the effective vertical stress at depth  $z$  will be

$$\sigma = (\gamma_{sat} - \gamma_w)z = \gamma' z \text{ where } \gamma' \text{ is the buoyant unit weight of the soil.}$$

### 3.1.3 RESPONSE OF EFFECTIVE STRESS TO A CHANGE IN TOTAL STRESS

As an illustration of how effective stress responds to a change in total stress, consider the case of a fully saturated soil subject to an increase in total vertical stress and in which the lateral strain is zero, volume change being entirely due to deformation of the soil in the vertical direction. This condition may be assumed in practice when there is a change in total vertical stress over an area which is large compared with the thickness of the soil layer in question. It is assumed initially that the pore water pressure is constant at a value governed by a constant position of the water table. This initial value is called the static pore water pressure ( $u_s$ ). When the total vertical stress is increased, the solid particles immediately try to take up new positions closer together. However, if water is incompressible and the soil is laterally confined, no such particle rearrangement, and therefore no increase in the inter particle forces, is possible unless some of the pore water can escape. Since the pore water is resisting the particle rearrangement the pore water pressure is increased above the static value immediately the increase in total stress takes place. The increase in pore water pressure will be equal to the increase in total vertical stress, i.e. the increase in total vertical stress is carried entirely by the pore water. Note that if the lateral strain were not zero some degree of particle rearrangement would be possible, resulting in an immediate increase in effective vertical stress and the increase in pore water pressure would be less than the increase in total vertical stress. The increase in pore water pressure causes a pressure gradient, resulting in a transient flow of pore water towards a free-draining boundary of the soil layer. This flow or drainage will continue until the pore water pressure again becomes equal to the value governed by the position of the water table.

The component of pore water pressure above the static value is known as the excess pore water pressure ( $u_e$ ). It is possible, however, that the position of the water table will have changed during the time necessary for drainage to take place, i.e. the datum

JAIRUBAA COLLEGE OF ENGINEERING, TRUBBUPUR  
 In such cases the excess pore water pressure should be expressed to the static value governed by the new water table position. At any time during drainage the overall pore water pressure ( $u$ ) is equal to the sum of the static and excess components, i.e.

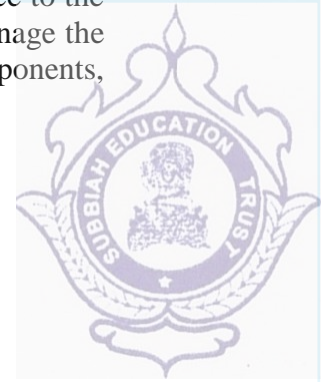

## Elasticity

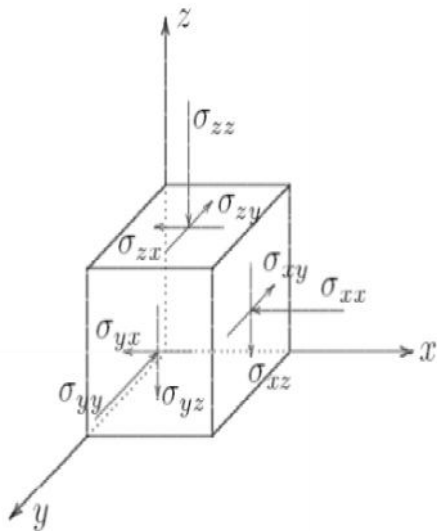

$$\epsilon_{xx} = -\frac{1}{E}[\sigma_{xx} - \nu(\sigma_{yy} + \sigma_{zz})],$$

$$\epsilon_{yy} = -\frac{1}{E}[\sigma_{yy} - \nu(\sigma_{zz} + \sigma_{xx})],$$

$$\epsilon_{zz} = -\frac{1}{E}[\sigma_{zz} - \nu(\sigma_{xx} + \sigma_{yy})],$$

$$\epsilon_{xy} = -\frac{1+\nu}{E}\sigma_{xy},$$

$$\epsilon_{yz} = -\frac{1+\nu}{E}\sigma_{yz},$$

$$\epsilon_{zx} = -\frac{1+\nu}{E}\sigma_{zx},$$

$\nu$  is Poisson's ratio

$E$  is the modulus of elasticity (Young's modulus)

## Stress Distribution: Concentrated load

### Boussinesq Analysis

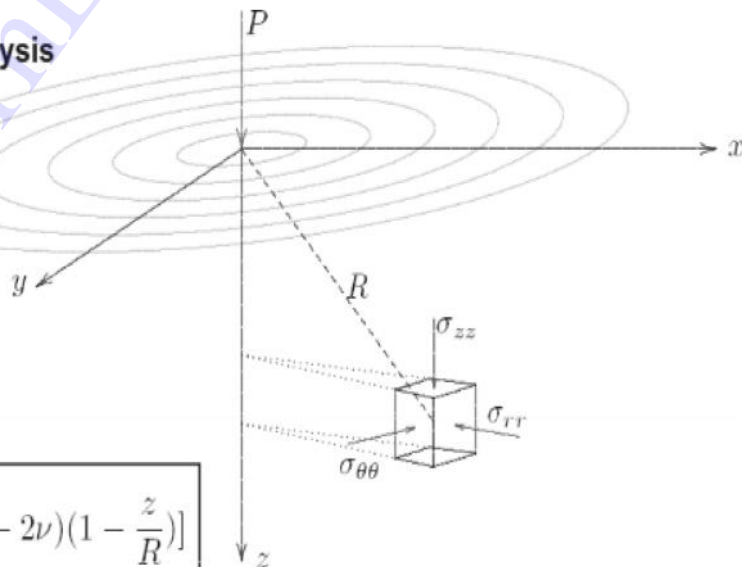

$$u_r = \frac{P(1+\nu)}{2\pi ER} \left[ \frac{r^2 z}{R^3} - (1-2\nu) \left(1 - \frac{z}{R}\right) \right]$$

$$u_\theta = 0,$$

$$\rightarrow u_z = \frac{P(1+\nu)}{2\pi ER} \left[ 2(1-\nu) + \frac{z^2}{R^2} \right].$$

$$z = 0 : u_z = \frac{P(1-\nu^2)}{\pi ER}$$



$$\sigma_{zz} = \frac{3P}{2\pi} \frac{z^3}{R^5},$$

$$\sigma_{rr} = \frac{P}{2\pi} \left[ \frac{3r^2 z}{R^5} - (1 - 2\nu) \frac{1}{R(R+z)} \right],$$

$$\sigma_{\theta\theta} = \frac{P}{2\pi} \frac{1 - 2\nu}{R^2} \left( \frac{R}{R+z} - \frac{z}{R} \right),$$

$$\sigma_{rz} = \frac{3P}{2\pi} \frac{rz^2}{R^5}.$$

Where,  $r = \sqrt{x^2 + y^2}$       $R = \sqrt{x^2 + y^2 + z^2}$

### 3.2.1 Vertical Concentration Load

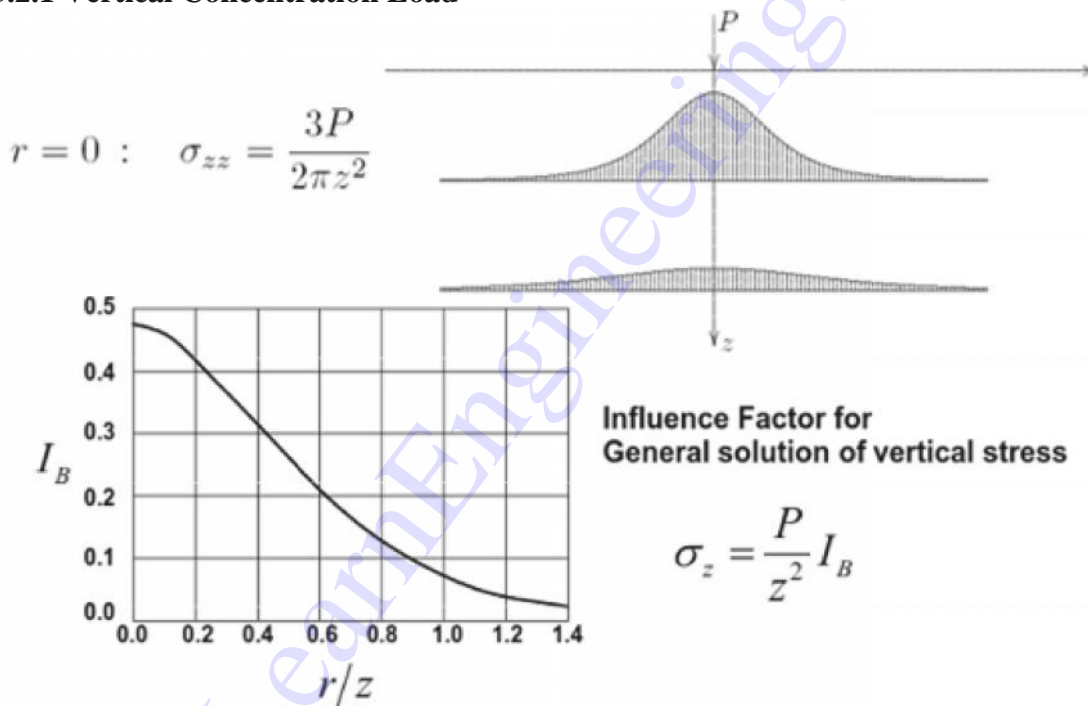

### 3.3 Vertical Stress: Uniformly Distributed Circular Load Vertical Stress: Uniformly Distributed Circular Load

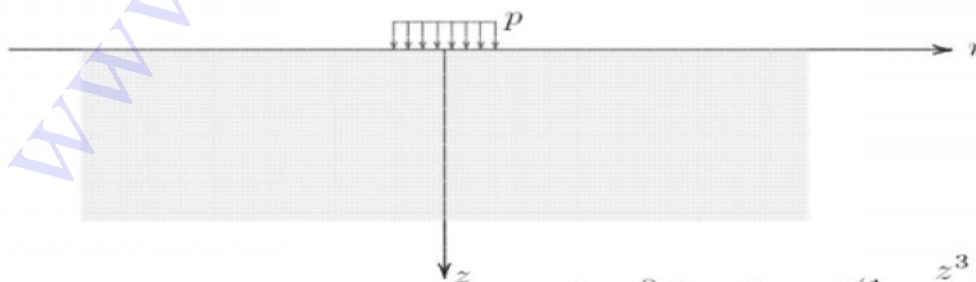

$$r = 0 : \sigma_{zz} = p \left( 1 - \frac{z^3}{b^3} \right),$$

$$r = 0 : \sigma_{rr} = p \left[ (1 + \nu) \frac{z}{b} - \frac{1}{2} \left( 1 - \frac{z^3}{b^3} \right) \right]$$

$$b = \sqrt{z^2 + a^2}$$



### 3.3.1 Vertical Stress: Uniformly Distributed Circular Load Rigid Plate on half Space

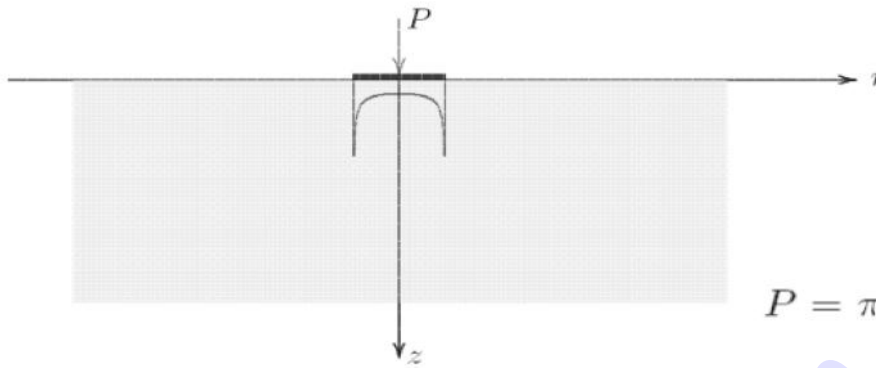

$$P = \pi a^2 \bar{p}$$

$$z = 0, 0 < r < a ; \quad \sigma_{zz} = \frac{\frac{1}{2}\bar{p}}{\sqrt{1 - r^2/a^2}}$$

$$z = 0, 0 < r < a ; \quad u_z = \frac{\pi}{2} (1 - \nu^2) \frac{\bar{p}a}{E}$$

### 3.3.2 Vertical Stress: Rectangular Area

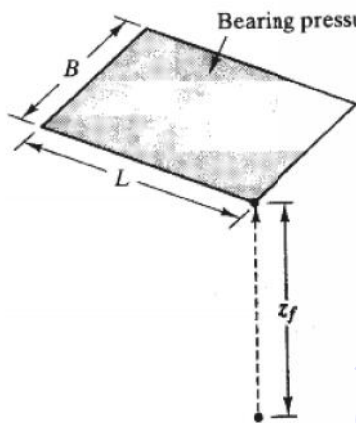

If  $B^2 + L^2 + z_f^2 < B^2 L^2 / z_f^2$ :

$$I_\sigma = \frac{1}{4\pi} \left[ \left( \frac{2BLz_f \sqrt{B^2 + L^2 + z_f^2}}{z_f^2 (B^2 + L^2 + z_f^2) + B^2 L^2} \right) \left( \frac{B^2 + L^2 + 2z_f^2}{B^2 + L^2 + z_f^2} \right) + \pi - \sin^{-1} \frac{2BLz_f \sqrt{B^2 + L^2 + z_f^2}}{z_f^2 (B^2 + L^2 + z_f^2) + B^2 L^2} \right]$$

Otherwise:

$$I_\sigma = \frac{1}{4\pi} \left[ \left( \frac{2BLz_f \sqrt{B^2 + L^2 + z_f^2}}{z_f^2 (B^2 + L^2 + z_f^2) + B^2 L^2} \right) \left( \frac{B^2 + L^2 + 2z_f^2}{B^2 + L^2 + z_f^2} \right) + \sin^{-1} \frac{2BLz_f \sqrt{B^2 + L^2 + z_f^2}}{z_f^2 (B^2 + L^2 + z_f^2) + B^2 L^2} \right]$$

### 3.3.3 Vertical Stress: Rectangular Area

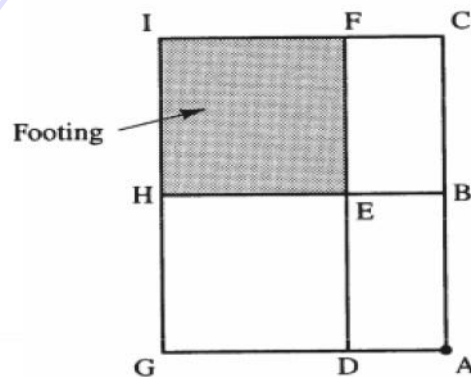

To Compute Stress at Point A Due to Load from Footing EFHI:  
 $(\Delta\sigma_v')_A = (\Delta\sigma_v')_{ACGI} - (\Delta\sigma_v')_{ACDF} - (\Delta\sigma_v')_{ABGH} + (\Delta\sigma_v')_{ABDE}$

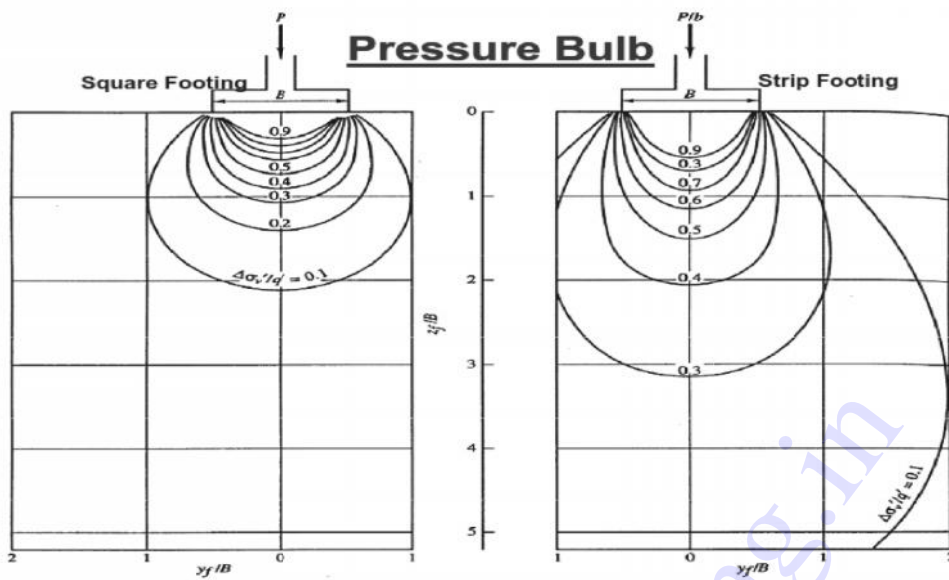

3.5 New mark's chart

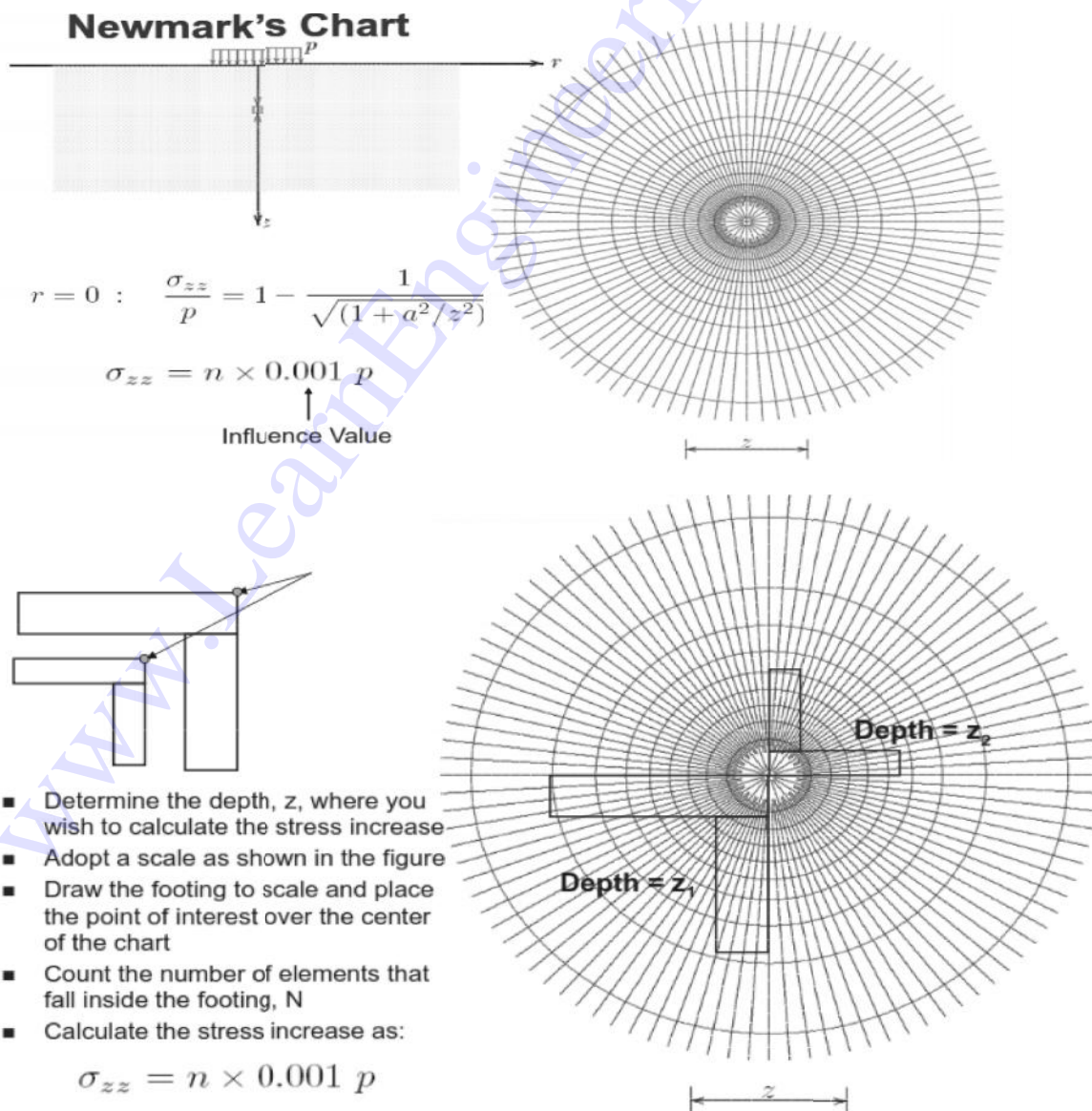



### Terzaghi's Theory of One Dimensional Consolidation?

The theoretical concept of the consolidation process was developed by Terzaghi in the development of the mathematical statement of the consolidation process. The following

- soil homogenous and fully saturated
- Deformation of the soil is due entirely to change in volume
- Darcy's law for the velocity of flow of water through soil is perfectly valid.
- Coefficient of permeability is constant during consolidation
- Load is applied deformation occurs only in direction
- The change in thickness of the layer during consolidation is insignificant.

a Clay layer of thickness  $H$  between two layer of sand which serves as drainage face. When the layer is subjected to a pressure increment  $\Delta\sigma$ , excess hydrostatic pressure application whole of the consolidating pressure  $\Delta\sigma$  is carried by the pore water so that hydrostatic pressure to is  $a_0$  equal  $\Delta\sigma$ .

$$h = \frac{\bar{u}}{\gamma\omega} \quad \text{(i)}$$

$$i = \frac{\partial h}{\partial z} = \frac{1}{\gamma\omega} \frac{\partial \bar{u}}{\partial z} \quad \text{(ii)}$$

$$V = Ki = \frac{K}{\gamma\omega} \frac{\partial \bar{u}}{\partial z} \quad \text{(iii)}$$

Change of velocity along depth layer.

$$\frac{\partial v}{\partial z} = \frac{K}{\gamma\omega} \frac{\partial^2 \bar{u}}{\partial z^2} \quad \text{(iv)}$$

The velocity of the exist will be equal to  $V + \frac{\partial v}{\partial z} dz$

The quantity of water leaving soil elements

$$= \left( V + \frac{\partial v}{\partial z} dz \right) \quad \text{(v)}$$

$$\Delta q = \frac{\partial v}{\partial z} dx dy dz \quad \text{(vi)}$$

$$\Delta v = -mvV_0 \Delta\sigma^1 \quad \text{(vii)}$$

$$\frac{\partial(\Delta v)}{\partial t} = -mvdxdydz \frac{\partial(\Delta\sigma^1)}{\partial t} \quad \text{(viii)}$$



$$\frac{\partial v}{\partial z} = -mv \frac{\partial(\Delta\sigma^1)}{\partial t}$$

$$\Delta\sigma = \Delta\sigma^1 + \bar{u}$$

$$\frac{\partial(\Delta\sigma^1)}{\partial t} = -\frac{\partial\bar{u}}{\partial t}$$

(i) and (ix)

$$\frac{\partial v}{\partial z} = mv \frac{\partial\bar{u}}{\partial t}$$

(iv) and (x)

$$\frac{\partial\bar{u}}{\partial t} = \frac{K}{mv\gamma\omega} \frac{\partial^2\bar{u}}{\partial z^2}$$

$$\frac{\partial\bar{u}}{\partial t} = C_v \frac{\partial^2\bar{u}}{\partial z^2}$$

$C_v$  = Coefficient of consolidation

$$= \frac{K}{mv\gamma\omega}$$

$$= \frac{K(1+e_0)}{a_v\gamma\omega}$$

Basic differential equation of consolidation which related the rates of changes of excess hydrostatic pressure is the rate of expulsion of excess pore water loaded from a unit volume of soil during the same time interval. The term coefficient of consolidation  $e_v$  used in the equation is adopted to indicate the combined effects of permeability and compressibility of soil on the rates of volume change  $C_v$  on  $\text{cm}^2/\text{sec}$ .



Shear strength of cohesive and cohesionless soils – Mohr – Coulomb failure theory  
 Measurement of shear strength, direct shear – Triaxial compression, UCC and Vane shear tests – Pore pressure parameters – cyclic mobility – Liquefaction.

**4.1 Necessity of Studying Shear Strength of Soils:**

Soil failure usually occurs in the form of “shearing” along internal surface within the soil. Thus, structural strength is primarily a function of shear strength.

**4.2 Shear Strength:**

The strength of a material is the greatest stress it can sustain

The safety of any geotechnical structure is dependent on the strength of the soil

If the soil fails, the structure founded on it can collapse

**Thus shear strength is “The capacity of a material to resist the internal and external forces which slide past each other”**

**4.2.1 Significance of Shear Strength:**

Engineers must understand the nature of shearing resistance in order to analyze soil stability problems such as;

- Bearing capacity
- Slope stability
- Lateral earth pressure on earth-retaining structures
- Pavement

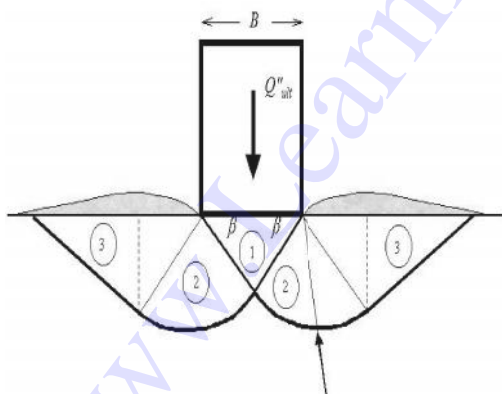

Shear Failure under Foundation Load  
 Shear



Transcona Grain Elevator, Canada  
 (Oct. 18, 1913) - Typical Example of

Failure of foundation

soil

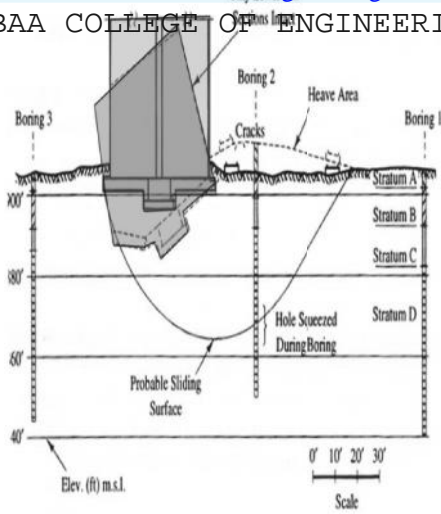

Failure of a house due to Shear failure of foundation soil

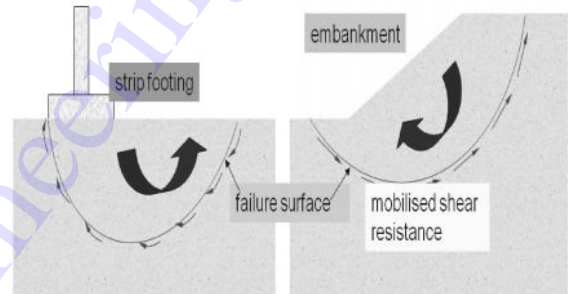
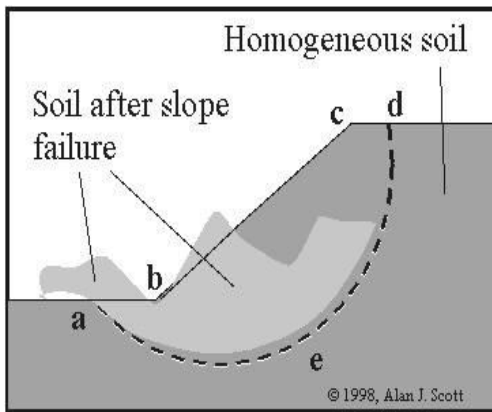

Thus shear strength of soil is “The capacity of a soil to resist the internal and external forces which slide past each other”

#### 4.2.2 Shear Strength in Soils:

The shear strength of a soil is its resistance to shearing stresses.

It is a measure of the soil resistance to deformation by continuous displacement of its individual soil particles.

Shear strength in soils depends primarily on interactions between particles.

Shear failure occurs when the stresses between the particles are such that they slide or roll past each other

#### 4.2.3 Components of shear strength of soils

Soil derives its shear strength from two sources:

- Cohesion between particles (stress independent component)
  - Cementation between sand grains
  - Electrostatic attraction between clay particles
- Frictional resistance and interlocking between particles (stress dependent component)

it is the force of attraction between the particles binding them together. cohesion is present in clays and silts but is normally absent in sands and gravels. Cohesion (C), is a measure of the forces that cement particles of soils



### Angle of response

- The maximum slope at which loose, cohesionless material is stable

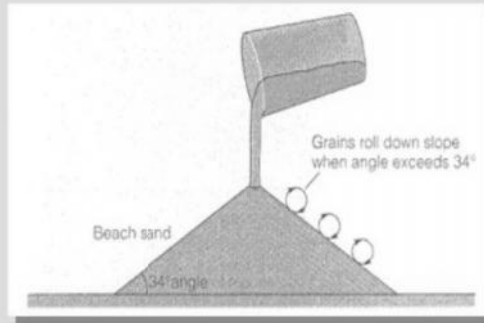

Angle of Repose determined by:

- Particle size (higher for large particles)
- Particle shape (higher for angular shapes)
- Shear strength (higher for higher shear strength)

#### 4.4 Stresses:

Gravity generates stresses (force per unit area) in the ground at different points. Stress on a plane at a given point is viewed in terms of two components:

**4.4.1 Normal stress ( ):** acts normal to the plane and tends to compress soil grains towards each other (volume change)

**4.4.2 Shear stress ( ):** acts tangential to the plane and tends to slide grains relative to each other (distortion and ultimately sliding failure)

#### 4.4.3 Factors Influencing Shear Strength:

The shearing strength is affected by:

- **Soil composition:** mineralogy, grain size and grain size distribution, shape of particles, pore fluid type and content, ions on grain and in pore fluid.
- **Initial state:** State can be describe by terms such as: loose, dense, over-consolidated, normally consolidated, stiff, soft, etc.
- **Structure:** Refers to the arrangement of particles within the soil mass; the manner in which the particles are packed or distributed. Features such as layers, voids, pockets, cementation, etc, are part of the structure.

#### 4.4.4 Formulation of Shear Strength of Soil:

- In reality, a complete shear strength formulation would account for all previously stated factors.
- Soil behavior is quite complex due to the possible variables stated.

Mohr presented in 1900 a theory of rupture of materials that was the result of a combination of both normal and shear stresses. The shear stress at failure is thus a function of normal stress and the Mohr circle is tangential to the functional relationship given by Coulomb



**Charles Mohr**

### The Mohr-Coulomb Failure Criterion:

This theory states that: “a material fails because of a critical combination of normal stress and shear stress, and not from their either maximum normal or shear stress alone”

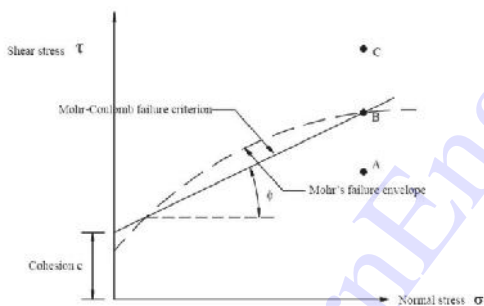

Comparison between the Mohr's failure envelope and the Mohr-Coulomb failure criterion.

$$\tau_f = c + \sigma \tan \phi$$

where  $c$  = cohesion, and

$\phi$  = angle of internal friction

This equation is known as the Mohr-Coulomb Failure Criterion.

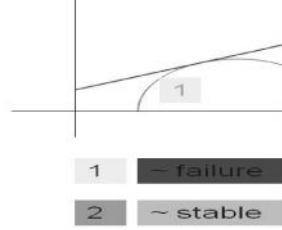
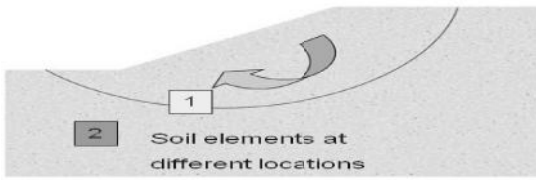
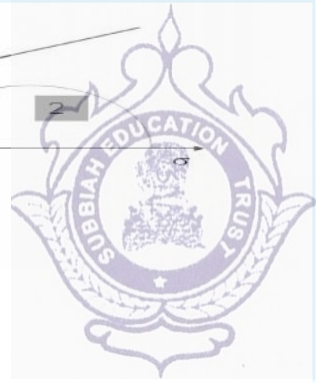

The soil element does not fail if the Mohr circle is contained within the envelope

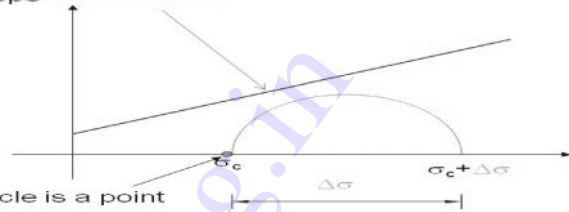
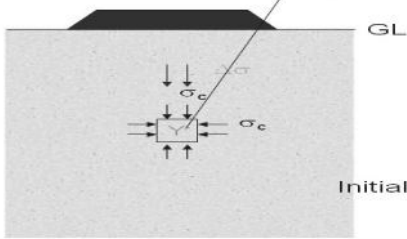

Initially, Mohr circle is a point

### Total Strength Envelope

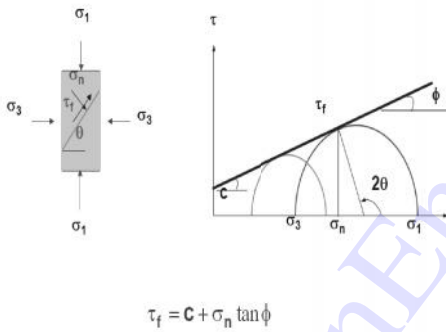

$$\tau_f = C + \sigma_n \tan \phi$$

### Effective Strength Envelope

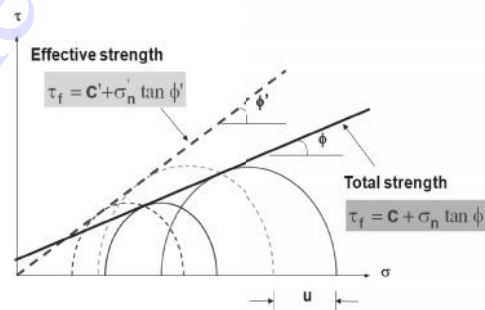

Effective strength

$$\tau_f = C' + \sigma_n' \tan \phi'$$

Total strength

$$\tau_f = C + \sigma_n \tan \phi$$

### Failure Envelopes

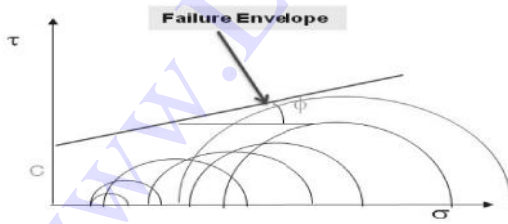

### Modified Failure Envelope

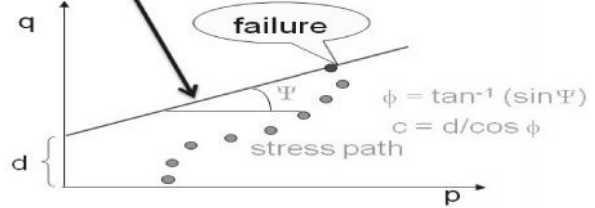

$$\phi = \tan^{-1}(\sin \Psi)$$

$$c = d / \cos \phi$$

During loading (shearing)....

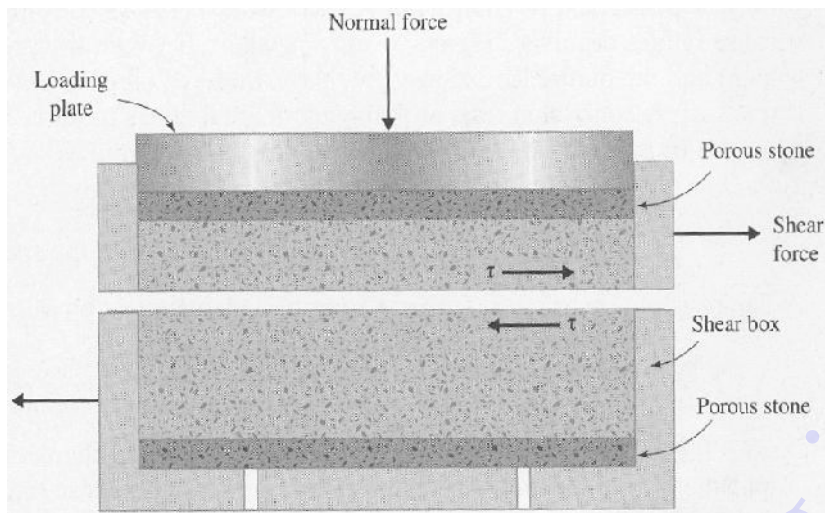

The shear strength parameters for a particular soil can be determined by means of laboratory tests on specimens taken from representative samples of the in-situ soil. Great care and judgment are required in the sampling operation and in the storage and handling of samples prior to testing, especially in the case of undisturbed samples where the object is to preserve the in-situ structure and water content of the soil. In the case of clays, test specimens may be obtained from tube or block samples, the latter normally being subjected to the least disturbance. Swelling of a clay specimen will occur due to the release of the in-situ total stresses. Shear strength test procedure is detailed in BS 1377 (Parts 7 and 8) [7].

The specimen is confined in a metal box (known as the shear box) of square or circular cross-section split horizontally at mid-height, a small clearance being maintained between the two halves of the box. Porous plates are placed below and on top of the specimen if it is fully or partially saturated to allow free drainage: if the specimen is dry, solid metal plates may be used. The essential features of the apparatus are shown diagrammatically in Figure. A vertical force ( $N$ ) is applied to the specimen through a loading plate and shear stress is gradually applied on a horizontal plane by causing the two halves of the box to move relative to each other, the shear force ( $T$ ) being measured together with the corresponding shear displacement ( $l$ ). Normally, the change in thickness ( $h$ ) of the specimen is also measured. If the initial thickness of the specimen is  $h_0$  then the shear strain can be represented by  $l/h_0$  and the volumetric strain ( $v$ ) by  $h/h_0$ . A number of specimens of the soil are tested, each under a different vertical force, and the value of shear stress at failure is plotted against the normal stress for each test. The shear strength parameters are then obtained from the best line fitting the plotted points.

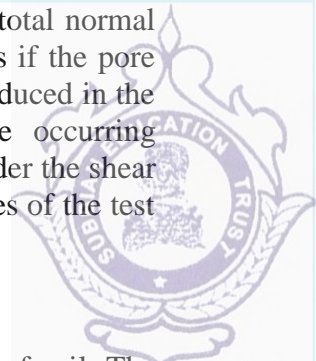

stress can be determined, although this is equal to the effective normal stress if the pore water pressure is zero. Only an approximation to the state of pure shear is produced in the specimen and shear stress on the failure plane is not uniform, failure occurring progressively from the edges towards the centre of the specimen. The area under the shear and vertical loads does not remain constant throughout the test. The advantages of the test are its simplicity and, in the case of sands, the ease of specimen preparation.

#### 4.6 The triaxial test

This is the most widely used shear strength test and is suitable for all types of soil. The test has the advantages that drainage conditions can be controlled, enabling saturated soils of low permeability to be consolidated, if required, as part of the test procedure, and pore water pressure measurements can be made. A cylindrical specimen, generally having a length/diameter ratio of 2, is used in the test and is stressed under conditions of axial symmetry in the manner shown in Figure. Typical specimen diameters are 38 and 100 mm. The main features of the apparatus are shown in Figure. The circular base has a central pedestal on which the specimen is placed, there being access through the pedestal for drainage and for the measurement of pore water pressure. A Perspex cylinder, sealed between a ring and the circular cell top, forms the body of the cell. The cell top has a central bush through which the loading ram passes. The cylinder and cell top clamp onto the base, a seal being made by means of an O-ring.

triaxial apparatus

#### Triaxial test

The specimen is placed on either a porous or a solid disc on the pedestal of the apparatus. A loading cap is placed on top of the specimen and the specimen is then sealed in a rubber membrane, O-rings under tension being used to seal the membrane to the pedestal and the loading cap. In the case of sands, the specimen must be prepared in a rubber membrane inside a rigid former which fits around the pedestal. A small negative pressure is applied to the pore water to maintain the stability of the specimen while the former is removed prior to the application of the all-round pressure. A connection may also be made through the loading cap to the top of the specimen, a flexible plastic tube leading from the loading cap to the base of the cell; this connection is normally used for the application of back pressure (as described later in this section). Both the top of the loading cap and the lower end of the loading ram have coned seating, the load being transmitted through a steel ball. The specimen is subjected to an all-round fluid pressure in the cell, consolidation is allowed to take place, if appropriate,

through the top or bottom of the specimen takes place, usually on a diagonal plane. The load is measured by means of a load ring or by a load transducer fitted either inside or outside the cell. The system for applying the all-round pressure must be capable of compensating for pressure changes due to cell leakage or specimen volume change.

In the triaxial test, consolidation takes place under equal increments of total stress normal to the end and circumferential surfaces of the specimen. Lateral strain in the specimen is not equal to zero during consolidation under these conditions (unlike in the odometer test, as described in Section). Dissipation of excess pore water pressure takes place due to drainage through the porous disc at the bottom (or top) of the specimen. The drainage connection leads to an external burette, enabling the volume of water expelled from the specimen to be measured. The datum for excess pore water pressure is therefore atmospheric pressure, assuming that the water level in the burette is at the same height as the centre of the specimen. Filter paper drains, in contact with the end porous disc, are some-times placed around the circumference of the specimen; both vertical and radial drainage then take place and the rate of dissipation of excess pore water pressure is increased.

The all-round pressure is taken to be the minor principal stress and the sum of the all-round pressure and the applied axial stress as the major principal stress, on the basis that there are no shear stresses on the surfaces of the specimen. The applied axial stress is thus referred to as the principal stress difference (also known as the deviator stress). The intermediate principal stress is equal to the minor principal stress; therefore, the stress conditions at failure can be represented by a Mohr circle. If a number of specimens are tested, each under a different value of all-round pressure, the failure envelope can be drawn and the shear strength parameters for the soil determined. In calculating the principal stress difference, the fact that the average cross-sectional area ( $A$ ) of the specimen does not remain constant throughout the test must be taken into account. If the original cross-sectional area of the specimen is  $A'$  and the original volume is  $V'$  then, if the volume of the specimen decreases during the test.

#### **4.6.1 Pore water pressure measurement**

The pore water pressure in a triaxial specimen can be measured, enabling the results to be expressed in terms of effective stress; conditions of no flow either out of or into the specimen must be maintained, otherwise the correct pressure will be modified. Pore water pressure is normally measured by means of an electronic pressure transducer. A change in pressure produces a small deflection of the transducer diaphragm, the corresponding strain being calibrated against pressure. The connection between the specimen and the transducer must be filled with de-aired water (produced by boiling water in a near vacuum) and the system should undergo negligible volume change under pressure. If the specimen is partially saturated a fine porous ceramic disc must be sealed into the pedestal of the cell if the correct pore water pressure is to be measured. Depending on the pore size of the ceramic, only pore water can flow through the disc, provided the difference between the pore air and pore water pressures is below a certain value known as the air entry value of the disc. Under undrained conditions the ceramic disc will remain fully saturated with water, provided the air entry value is high enough, and enabling the correct pore water pressure to be measured. The use of a coarse porous disc, as normally used for a fully saturated soil, would result in the measurement of the pore air pressure in a partially saturated soil.

#### **4.7 Types of test**

Many variations of test procedure are possible with the triaxial apparatus but the three principal types of test are as follows:

At a **good pressure** and then the principal stress difference is applied immediately, with no drainage being permitted at any stage of the test.

**4.7.2 Consolidated–Undrained:** Drainage of the specimen is permitted under a specified all-round pressure until consolidation is complete; the principal stress difference is then applied with no drainage being permitted. Pore water pressure measurements may be made during the undrained part of the test.

**4.7.3 Drained:** Drainage of the specimen is permitted under a specified all round pressure until consolidation is complete; with drainage still being permitted, the principal stress difference is then applied at a rate slow enough to ensure that the excess pore water pressure is maintained at zero.

Shear strength parameters determined by means of the above test procedures are relevant only in situations where the field drainage conditions correspond to the test conditions. The shear strength of a soil under undrained conditions is different from that under drained conditions. The undrained strength can be expressed in terms of total stress in the case of fully saturated soils of low permeability, the shear strength parameters being denoted by  $c_u$  and  $\phi_u$ . The drained strength is expressed in terms of the effective stress parameters  $c_u$  and  $\phi_u$ .

The vital consideration in practice is the rate at which the changes in total stress (due to construction operations) are applied in relation to the rate of dissipation of excess pore water pressure, which in turn is related to the permeability of the soil. Undrained conditions apply if there has been no significant dissipation during the period of total stress change; this would be the case in soils of low permeability such as clays immediately after the completion of construction. Drained conditions apply in situations where the excess pore water pressure is zero; this would be the case in soils of low permeability after consolidation is complete and would represent the situation a long time, perhaps many years, after the completion of construction. The drained condition would also be relevant if the rate of dissipation were to keep pace with the rate of change of total stress; this would be the case in soils of high permeability such as sands. The drained condition is therefore relevant for sands both immediately after construction and in the long term. Only if there were extremely rapid changes in total stress (e.g. as the result of an explosion or an earthquake) would the undrained condition be relevant for a sand. In some situations, partially drained conditions may apply at the end of construction, perhaps due to a very long construction period or to the soil in question being of intermediate permeability. In such cases the excess pore water pressure would have to be estimated and the shear strength would then be calculated in terms of effective stress.

#### **4.8 The vane shear test**

This test is used for the in-situ determination of the undrained strength of intact, fully saturated clays; the test is not suitable for other types of soil. In particular, this test is very suitable for soft clays, the shear strength of which may be significantly altered by the sampling process and subsequent handling. Generally, this test is only used in clays having undrained strengths less than 100 kN/m<sup>2</sup>. This test may not give reliable results if the clay contains sand or silt laminations. Details of the test are given in BS 1377 (Part 9). The equipment consists of a Stainless steel vane (Figure) of four thin rectangular blades, carried on the end of

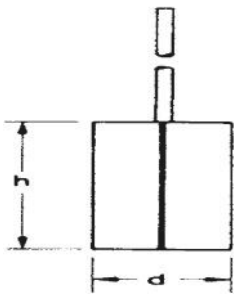

a high-tensile steel rod; the rod is enclosed by a sleeve packed with grease. The length of the vane is equal to twice its overall width, typical dimensions being 150 mm by 75 mm and 100 mm by 50 mm. preferably the diameter of the rod should not exceed 12.5 mm.

The vane and rod are pushed into the clay below the bottom of a borehole to a depth of at least three times the borehole diameter; if care is taken this can be done without appreciable disturbance of the clay. Steady bearings are used to keep the rod and sleeve central in the borehole casing. The test can also be carried out in soft clays, without a borehole, by direct penetration of the vane from ground level; in this case a shoe is required to protect the vane during penetration.

Torque is applied gradually to the upper end of the rod by means of suitable equipment until the clay fails in shear due to rotation of the vane. Shear failure takes place over the surface and ends of a cylinder having a diameter equal to the overall width of the vane. The rate of rotation of the vane should be within the range of 6–12 per minute. The shear strength is calculated from the expression

$$T = \pi c_u \left( \frac{d^2 h}{2} + \frac{d^3}{6} \right)$$

where  $T$  is the torque at failure,  $d$  the overall vane width and  $h$  the vane length. However, the shear strength over the cylindrical vertical surface may be different from that over the two horizontal end surfaces, as a result of anisotropy. The shear strength is normally determined at intervals over the depth of interest. If, after the initial test, the vane is rotated rapidly through several revolutions the clay will become remoulded and the shear strength in this condition could then be determined if required. Small, hand-operated vane testers are also available for use in exposed clay strata.

#### 4.9 Special tests

In practice, there are very few problems in which a state of axial symmetry exists as in the triaxial test. In practical states of stress the intermediate principal stress is not usually equal to the minor principal stress and the principal stress directions can undergo rotation as the failure condition is approached. A common condition is that of plane strain in which the strain in the direction of the intermediate principal stress is zero due to restraint imposed by virtue of the length of the structure in question. In the triaxial test, consolidation proceeds under equal all-round pressure (i.e. isotropic consolidation) whereas in-situ consolidation takes place under anisotropic stress conditions.

Tests of a more complex nature, generally employing adaptations of triaxial equipment, have been devised to simulate the more complex states of stress encountered in practice but these are used principally in research. The plane strain test uses a prismatic

mainly controlled by means of two rigid side plates tied together. The all-round pressure is the minor principal stress and the sum of the applied axial stress and the all-round pressure the major principal stress. A more sophisticated test, also using a prismatic specimen, enables the values of all three principal stresses to be controlled independently, two side pressure bags or jacks being used to apply the intermediate principal stress. Independent control of the three principal stresses can also be achieved by means of tests on soil specimens in the form of hollow cylinders in which different values of external and internal fluid pressure can be applied in addition to axial stress. Torsion applied to the hollow cylinders results in the rotation of the principal stress directions. Because of its relative simplicity it seems likely that the triaxial test will continue to be the main test for the determination of shear strength characteristics. If considered necessary, corrections can be applied to the results of triaxial tests to obtain the characteristics under more complex states of stress.

### 4.9.1 SHEAR STRENGTH OF SANDS

The shear strength characteristics of a sand can be determined from the results of either direct shear tests or drained triaxial tests, only the drained strength of a sand normally being relevant in practice. The characteristics of dry and saturated sands are the same, provided there is zero excess pore water pressure in the case of saturated sands. Typical curves relating shear stress and shear strain for initially dense and loose sand specimens in direct shear tests are shown in Figure. Similar curves are obtained relating principal stress difference and axial strain in drained triaxial compression tests.

In a dense sand there is a considerable degree of interlocking between particles. Before shear failure can take place, this interlocking must be overcome in addition to the frictional resistance at the points of contact. In general, the degree of interlocking is greatest in the case of very dense, well-graded sands consisting of angular particles. The characteristic stress-strain curve for an initially dense sand shows a peak stress at a relatively low strain and thereafter, as interlocking is

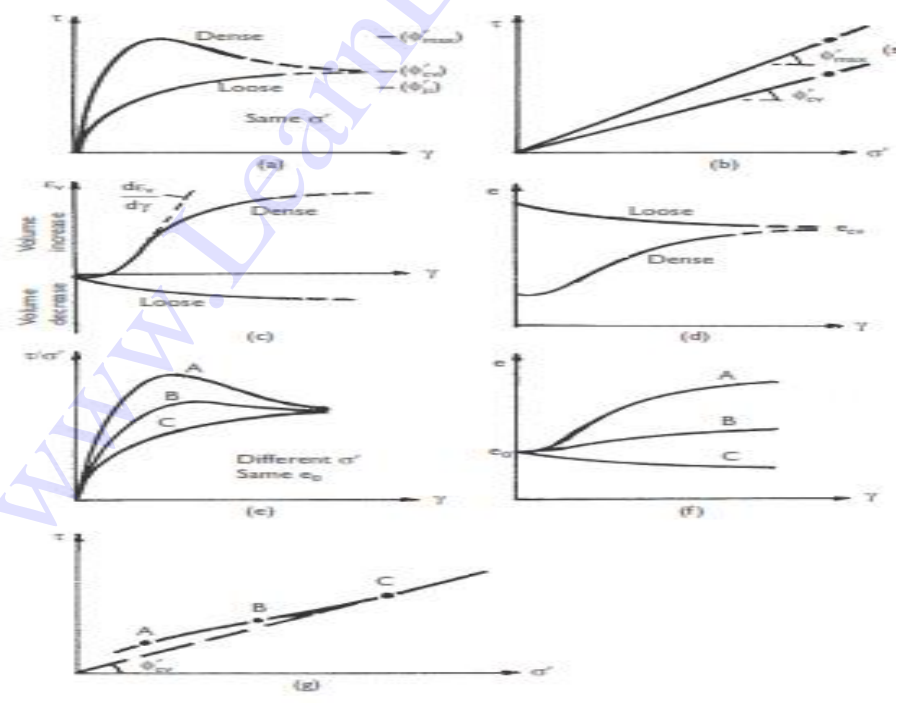

Shear strength characteristics of sand.

Large increase in pore water pressure produces no increase in the volume of the specimen during shearing as characterized by the relationship, shown in Figure , between volumetric strain and shear strain in the direct shear test.

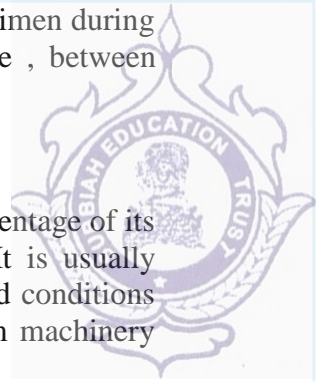

## 4.10 Liquefaction

Liquefaction is a phenomenon in which loose saturated sand loses a large percentage of its shear strength and develops characteristics similar to those of a liquid. It is usually induced by cyclic loading of relatively high frequency, resulting in undrained conditions in the sand. Cyclic loading may be caused, for example, by vibrations from machinery and, more seriously, by earth tremors.

Loose sand tends to compact under cyclic loading. The decrease in volume causes an increase in pore water pressure which cannot dissipate under undrained conditions. Indeed, there may be a cumulative increase in pore water pressure under successive cycles of loading. If the pore water pressure becomes equal to the maximum total stress component, normally the overburden pressure, the value of effective stress will be zero, i.e. inter particle forces will be zero, and the sand will exist in a liquid state with negligible shear strength. Even if the effective stress does not fall to zero the reduction in shear strength may be sufficient to cause failure.

Liquefaction may develop at any depth in a sand deposit where a critical combination of in-situ density and cyclic deformation occurs. The higher the void ratio of the sand and the lower the confining pressure the more readily liquefaction will occur. The larger the strains produced by the cyclic loading the lower the number of cycles required for liquefaction.

### 4.10.1 PORE PRESSURE COEFFICIENTS

Pore pressure coefficients are used to express the response of pore water pressure to changes in total stress under undrained conditions and enable the initial value of excess pore water pressure to be determined. Values of the coefficients may be determined in the laboratory and can be used to predict pore water pressures in the field under similar stress conditions.

#### Increment of isotropic stress

Consider an element of soil, of volume  $V$  and porosity  $n$ , in equilibrium under total principal stresses  $\sigma_1, \sigma_2, \sigma_3$ , as shown in Figure, the pore pressure being  $u_0$ . The element is subjected to equal increases in total stress  $\sigma_3$  in each direction, resulting in an immediate increase  $u_3$  in pore pressure.

Slope failure mechanisms – Types - infinite slopes – finite slopes – Total stress analysis for saturated clay – Fellenius method - Friction circle method – Use of stability number - slope protection measures.

## 5.1 INTRODUCTION

Gravitational and seepage forces tend to cause instability in natural slopes, in slopes formed by excavation and in the slopes of embankments. The most important types of slope failure are illustrated in Figure. In rotational slips the shape of the failure surface in section may be a circular arc or a non-circular curve. In general, circular slips are associated with homogeneous, isotropic soil conditions and non-circular slips with non-homogeneous conditions. Translational and compound slips occur where the form of the failure surface is influenced by the presence of an adjacent stratum of significantly different strength, most of the failure surface being likely to pass through the stratum of lower shear strength. The form of the surface would also be influenced by the presence of discontinuities such as fissures and pre-existing slips. Translational slips tend to occur where the adjacent stratum is at a relatively shallow depth below the surface of the slope, the failure surface tending to be plane and roughly parallel to the slope. Compound slips usually occur where the adjacent stratum is at greater depth, the failure surface consisting of curved and plane sections. In most cases, slope stability can be considered as a two-dimensional problem, conditions of plane strain being assumed.

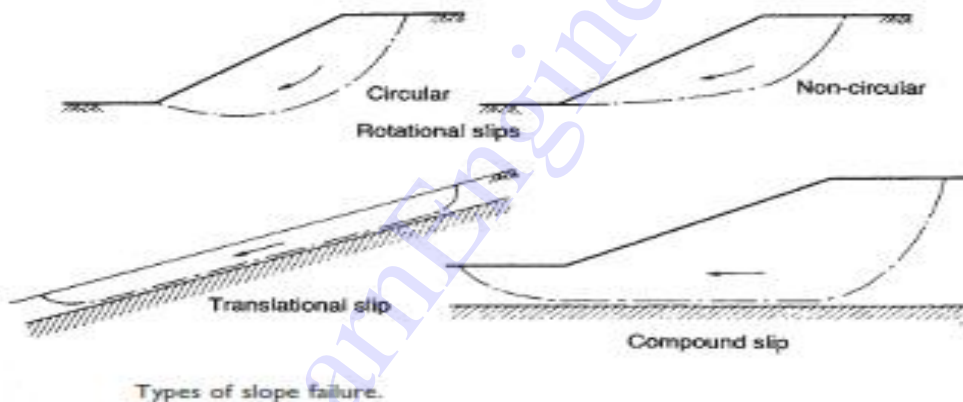

Design resisting moment. Characteristic values of shear strength parameters  $c'$  and  $\tan u'$  should be divided by factors 1.60 and 1.25, respectively. (However, the value of  $c'$  is zero if the critical-state strength is used.) The characteristic value of parameter  $c_u$  should be divided by 1.40. A factor of unity is appropriate for the self-weight of the soil and for pore water pressures. However, variable loads on the soil surface adjacent to the slope should be multiplied by a factor of 1.30.

The following limit states should be considered as appropriate:

- 1 Loss of overall stability due to slip failure.
- 2 Bearing resistance failure below embankments.
- 3 Internal erosion due to high hydraulic gradients and/or poor compaction.
- 4 Failure as a result of surface erosion.
- 5 Failure due to hydraulic uplift.
- 6 Excessive soil deformation resulting in structural damage to, or loss of service-ability of, adjacent structures, highways or services.

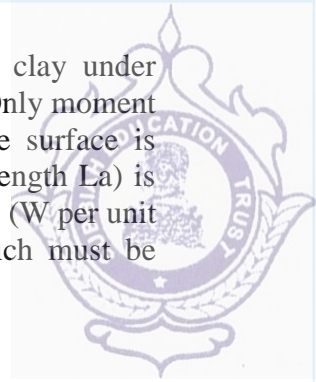

This analysis, in terms of total stress, covers the case of fully saturated clay under undrained conditions, i.e. for the condition immediately after construction. Only moment equilibrium is considered in the analysis. In section, the potential failure surface is assumed to be a circular arc. A trial failure surface (centre O, radius r and length  $L_a$ ) is shown in Figure. Potential instability is due to the total weight of the soil mass ( $W$  per unit length) above the failure surface. For equilibrium the shear strength which must be mobilized along the failure surface is expressed as

$$\tau_m = \frac{\pi}{F} = \frac{c_u}{F}$$

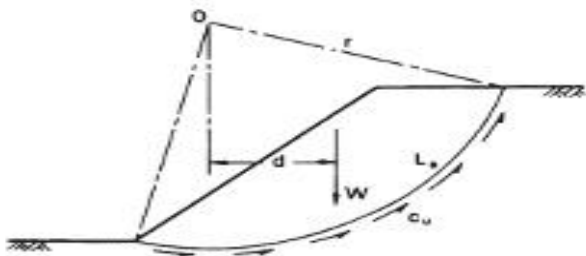

The  $\phi_u = 0$  analysis.

where  $F$  is the factor of safety with respect to shear strength. Equating moments about O

$$Wd = \frac{c_u}{F} L_a r$$

Therefore

$$F = \frac{c_u L_a r}{Wd}$$

The moments of any additional forces must be taken into account. In the event of a tension crack developing, the arc length  $L_a$  is shortened and a hydrostatic force will act normal to the crack if it fills with water. It is necessary to analyze the slope for a number of trial failure surfaces in order that the minimum factor of safety can be determined.

Based on the principle of geometric similarity, Taylor [19] published stability coefficients for the analysis of homogeneous slopes in terms of total stress. For a slope of height  $H$  the stability coefficient ( $N_s$ ) for the failure surface along which the factor of safety is a minimum is

$$Tm = \frac{\pi}{F} \cdot \frac{c_u}{F}$$

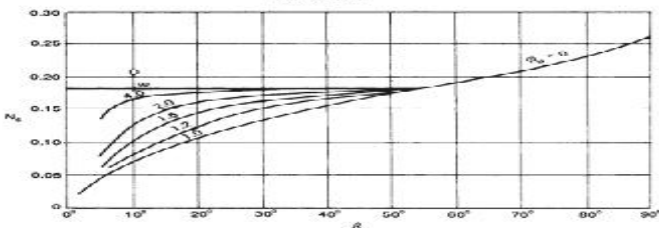
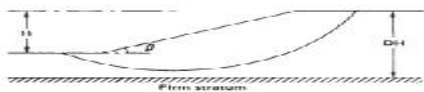

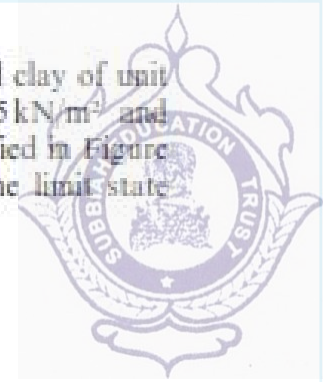

**Example**  
 A 45° slope is excavated to a depth of 8 m in a deep layer of saturated clay of unit weight 19 kN/m<sup>3</sup>; the relevant shear strength parameters are  $c_u = 65 \text{ kN/m}^2$  and  $\phi_u = 0$ . Determine the factor of safety for the trial failure surface specified in Figure 9.4. Check that no loss of overall stability will occur according to the limit state approach.

In Figure 9.4, the cross-sectional area ABCD is 70 m<sup>2</sup>.

Weight of soil mass =  $70 \times 19 = 1330 \text{ kN/m}$

The centroid of ABCD is 4.5 m from O. The angle AOC is 89½° and radius OC is 12.1 m. The arc length ABC is calculated as 18.9 m. The factor of safety is given by

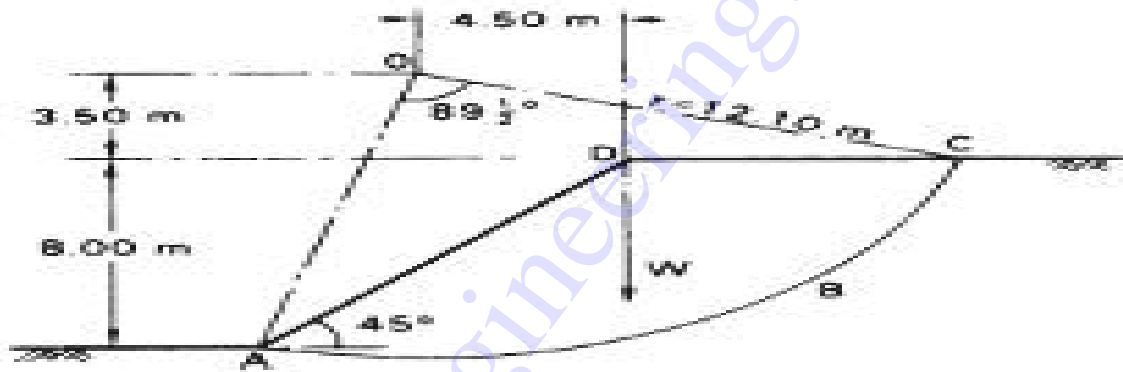

$$F = \frac{c_u L_{arc}}{Wd} = \frac{65 \times 18.9 \times 12.1}{1330 \times 4.5} = 2.48$$

This is the factor of safety for the trial failure surface selected and is not necessarily the minimum factor of safety. The minimum factor of safety can be estimated by using Equation. From Figure  $\alpha = 45^\circ$  and assuming that D is large, the value of  $N_s$  is 0.18. Then

$$F = \frac{c_u}{N_s \gamma H} = \frac{65}{0.18 \times 19 \times 8} = 2.37$$

Using the limit state method the characteristic value of undrained strength ( $c_{uk}$ ) is divided by a partial factor of 1.4. Thus the design value of the parameter ( $c_{ud}$ ) is  $65/1.40$  i.e. 46 kN/m<sup>2</sup>, hence

$$m = Wd = 1330 \times 4.5 = 5985 \text{ kNm}$$

Design disturbing moment per



The design disturbing moment is less than the design resisting moment; therefore the overall stability limit state is satisfied.

## 5.2 THE METHOD OF SLICES

In this method the potential failure surface, in section, is again assumed to be a circular arc with centre O and radius r. The soil mass (ABCD) above a trial failure surface

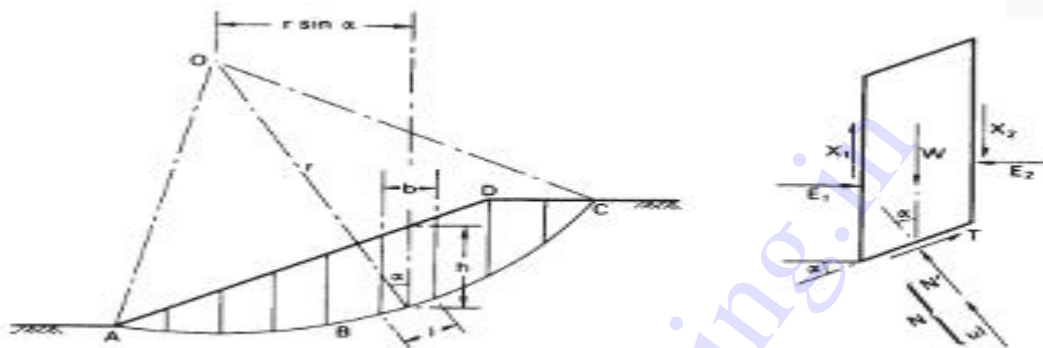

Figure 9.5 The method of slices.

(AC) is divided by vertical planes into a series of slices of width  $b$ , as shown in Figure 9.5. The base of each slice is assumed to be a straight line. For any slice the inclination of the base to the horizontal is  $\alpha$  and the height, measured on the centre-line, is  $h$ . The analysis is based on the use of a lumped factor of safety ( $F$ ), defined as the ratio of the available shear strength ( $\tau$ ) to the shear strength ( $T_m$ ) which must be mobilized to maintain a condition of limiting equilibrium, i.e.

$$F = \frac{\tau}{T_m}$$

The factor of safety is taken to be the same for each slice, implying that there must be mutual support between slices, i.e. forces must act between the slices.

The forces (per unit dimension normal to the section) acting on a slice are:

- 1 The total weight of the slice,  $W = \gamma bh$  ( $\gamma_{sat}$  where appropriate).
- 2 The total normal force on the base,  $N$  (equal to  $\sigma l$ ). In general this force has two components, the effective normal force  $N'$  (equal to  $\sigma' l$ ) and the boundary water force  $U$  (equal to  $ul$ ), where  $u$  is the pore water pressure at the centre of the base and  $l$  the length of the base.
- 3 The shear force on the base,  $T = \tau_m l$ .
- 4 The total normal forces on the sides,  $E_1$  and  $E_2$ .
- 5 The shear forces on the sides,  $X_1$  and  $X_2$ .

Any external forces must also be included in the analysis.

The problem is statically indeterminate and in order to obtain a solution assumptions must be made regarding the interslice forces  $E$  and  $X$ ; in general the resulting solution for factor of safety is not exact.

Considering moments about O, the sum of the moments of the shear forces  $T$  on the failure arc AC must equal the moment of the weight of the soil mass ABCD. For any slice the lever arm of  $W$  is  $r \sin \alpha$ , therefore

$$\Sigma Tr = \Sigma W r \sin \alpha$$

Now

$$T = \tau_m l = \frac{\pi}{F} l$$

$$\therefore \Sigma \frac{\pi}{F} l = \Sigma W \sin \alpha$$

$$\therefore F = \frac{\Sigma \tau_m l}{\Sigma W \sin \alpha}$$

For an effective stress analysis (in terms of tangent parameters  $c'$  and  $\phi'$ ):

$$F = \frac{\Sigma (c' + \sigma' \tan \phi') l}{\Sigma W \sin \alpha}$$

or

$$F = \frac{c' L_a + \tan \phi' \Sigma N'}{\Sigma W \sin \alpha}$$

where  $L_a$  is the arc length AC. Equation 9.3(a) is exact but approximations are introduced in determining the forces  $N'$ . For a given failure arc the value of  $F$  will depend on the way in which the forces  $N'$  are estimated.

However, the critical-state strength is normally appropriate in the analysis of slope stability, i.e.  $\phi' = \phi'_{cv}$  and  $c' = 0$ , therefore the factor of safety is given by

$$F = \frac{\tan \phi'_{cv} \Sigma N'}{\Sigma W \sin \alpha}$$

### The Fellenius (or Swedish) solution

In this solution it is assumed that for each slice the resultant of the interslice forces is zero. The solution involves resolving the forces on each slice normal to the base, i.e.

$$N' = W \cos \alpha - ul$$

Hence the factor of safety in terms of effective stress (Equation 9.3(a)) is given by

$$F = \frac{c' L_a + \tan \phi' \Sigma (W \cos \alpha - ul)}{\Sigma W \sin \alpha}$$

The components  $W \cos \alpha$  and  $W \sin \alpha$  can be determined graphically for each slice. Alternatively, the value of  $\alpha$  can be measured or calculated. Again, a series of trial





failure surfaces must be chosen in order to obtain the minimum factor of safety. This solution underestimates the factor of safety: the error, compared with more accurate methods of analysis, is usually within the range 5-20%.

For an analysis in terms of total stress the parameter  $c_u$  is used in Equation (with  $\phi_u = 0$ ) and the value of  $v$  is zero. The factor of safety then becomes

$$F = \frac{c_u l_s}{\Sigma W \sin \alpha}$$

As  $N$  does not appear in Equation 9.5, an exact value of  $F$  is obtained.

Use of the Fellenius method is not now recommended in practice.

#### The Bishop routine solution

In this solution it is assumed that the resultant forces on the sides of the slices are horizontal, i.e.

$$X_1 - X_2 = 0$$

For equilibrium the shear force on the base of any slice is

$$T = \frac{1}{F}(c'l + N' \tan \phi')$$

Resolving forces in the vertical direction:

$$W = N' \cos \alpha + ul \cos \alpha + \frac{c'l}{F} \sin \alpha + \frac{N'}{F} \tan \phi' \sin \alpha$$

$$\therefore N' = \frac{[W - (c'l/F) \sin \alpha - ul \cos \alpha]}{[\cos \alpha + (\tan \phi' \sin \alpha)/F]}$$

It is convenient to substitute

$$l = b \sec \alpha$$

From Equation 9.3(a), after some rearrangement,

$$F = \frac{1}{\Sigma W \sin \alpha} \sum \left[ \{c'b + (W - ub) \tan \phi'\} \frac{\sec \alpha}{1 + (\tan \alpha \tan \phi'/F)} \right]$$

Bishop [2] also showed how non-zero values of the resultant forces ( $X_1 - X_2$ ) could be introduced into the analysis but this refinement has only a marginal effect on the factor of safety.

The pore water pressure can be related to the total 'fill pressure' at any point by means of the dimensionless *pore pressure ratio*, defined as

$$r_u = \frac{u}{\gamma h}$$



$$r_u = \frac{u}{W/b}$$

Hence Equation 9.7 can be written as

$$F = \frac{1}{\Sigma W \sin \alpha} \sum \left[ \{c'b + W(1 - r_u) \tan \phi'\} \frac{\sec \alpha}{1 + (\tan \alpha \tan \phi' / F)} \right]$$

As the factor of safety occurs on both sides of Equation 9.9, a process of successive approximation must be used to obtain a solution but convergence is rapid.

Due to the repetitive nature of the calculations and the need to select an adequate number of trial failure surfaces, the method of slices is particularly suitable for solution by computer. More complex slope geometry and different soil strata can be introduced.

In most problems the value of the pore pressure ratio  $r_u$  is not constant over the whole failure surface but, unless there are isolated regions of high pore pressure, an average value (weighted on an area basis) is normally used in design. Again, the factor of safety determined by this method is an underestimate but the error is unlikely to exceed 7% and in most cases is less than 2%.

Spencer [18] proposed a method of analysis in which the resultant interslice forces are parallel and in which both force and moment equilibrium are satisfied. Spencer showed that the accuracy of the Bishop routine method, in which only moment equilibrium is satisfied, is due to the insensitivity of the moment equation to the slope of the interslice forces.

Dimensionless stability coefficients for homogeneous slopes, based on Equation 9.9, have been published by Bishop and Morgenstern [4]. It can be shown that for a given slope angle and given soil properties the factor of safety varies linearly with  $r_u$  and can thus be expressed as

$$F = m - nr_u$$

where  $m$  and  $n$  are the stability coefficients. The coefficients  $m$  and  $n$  are functions of  $\beta$ ,  $\phi'$ , depth factor  $D$  and the dimensionless factor  $c'/\gamma H$  (which is zero if the critical-state strength is used).

### ANALYSIS OF A PLANE TRANSLATIONAL SLIP

It is assumed that the potential failure surface is parallel to the surface of the slope and is at a depth that is small compared with the length of the slope. The slope can then be considered as being of infinite length, with end effects being ignored. The slope is inclined at angle  $\beta$  to the horizontal and the depth of the failure plane is  $z$ , as shown in section in Figure 9.7. The water table is taken to be parallel to the slope at a height of  $mz$  ( $0 < m < 1$ ) above the failure plane. Steady seepage is assumed to be taking place in a direction parallel to the slope. The forces on the sides of any vertical slice are equal and opposite, and the stress conditions are the same at every point on the failure plane.

In terms of effective stress, the shear strength of the soil along the failure plane (using the critical-state strength) is

$$\tau_f = (\sigma - u) \tan \phi'_{cr}$$

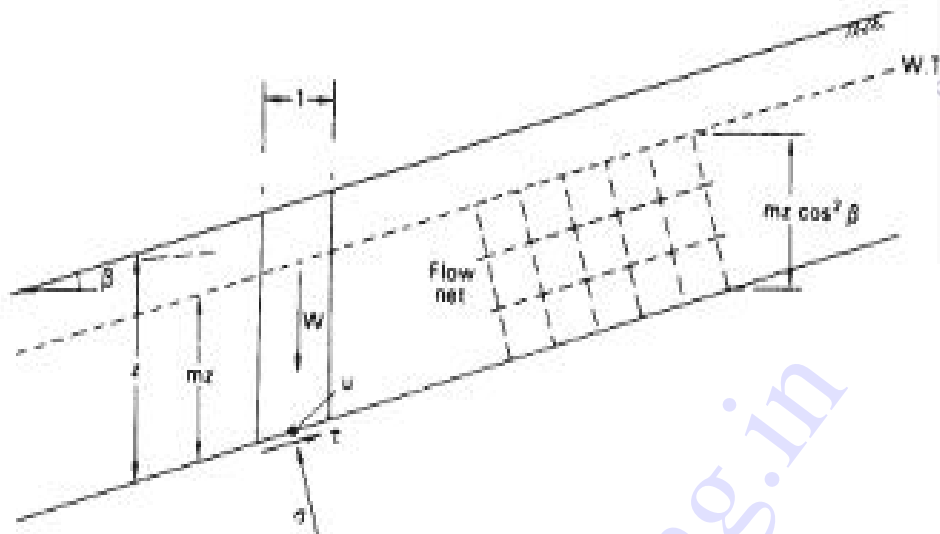

Figure 9.7 Plane translational slip.

and the factor of safety is

$$F = \frac{\tau_f}{\tau}$$

The expressions for  $\sigma$ ,  $\tau$  and  $u$  are

$$\sigma = \{(1 - m)\gamma + m\gamma_{sat}\}z \cos^2 \beta$$

$$\tau = \{(1 - m)\gamma + m\gamma_{sat}\}z \sin \beta \cos \beta$$

$$u = mz\gamma_w \cos^2 \beta$$

If the soil between the surface and the failure plane is not fully saturated (i.e.  $m = 0$ ) then

$$F = \frac{\tan \phi'_{cs}}{\tan \beta}$$

If the water table coincides with the surface of the slope (i.e.  $m = 1$ ) then

$$F = \frac{\gamma' \tan \phi'_{cs}}{\gamma_{sat} \tan \beta}$$

For a total stress analysis the shear strength parameter  $c_u$  is used (with  $\phi_u = 0$ ) and the value of  $u$  is zero.



**GENERAL METHODS OF ANALYSIS**

Morgenstern and Price [12] developed a general analysis in which all boundary and equilibrium conditions are satisfied and in which the failure surface may be any shape, circular, non-circular or compound. The ground surface is represented by a function  $y = z(x)$  and the trial failure surface by  $y = y(x)$  as shown in Figure 9.8. The forces acting on an infinitesimal slice of width  $dx$  are also shown in the figure. The forces are denoted as follows:

- $E'$  = effective normal force on a side of the slice,
- $X$  = shear force on a side,
- $P_w$  = boundary water force on a side,
- $dN'$  = effective normal force on the base of the slice,
- $dS$  = shear force on the base,
- $dP_b$  = boundary water force on the base,
- $dW$  = total weight of the slice.

The line of thrust of the effective normal forces ( $E'$ ) is represented by a function  $y = y'_1(x)$  and that of the internal water forces ( $P_w$ ) by  $y = h(x)$ . Two governing differential equations are obtained by equating moments about the mid-point of the

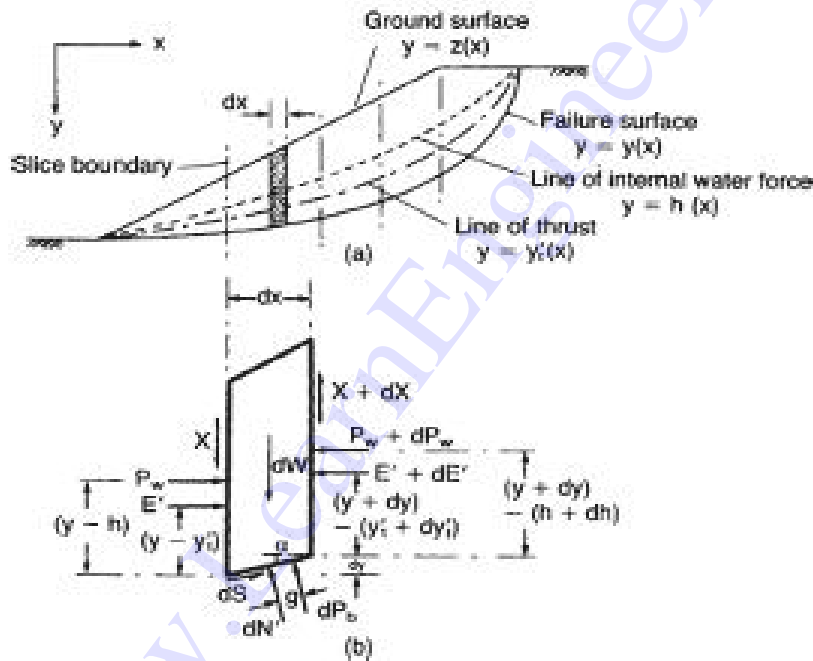

Figure 9.8 The Morgenstern-Price method.

base, and forces perpendicular and parallel to the base, to zero. The equations are simplified by working in terms of the total normal force ( $E$ ), where

$$E = E' + P_n$$

The position of force  $E$  on a side of the slice is obtained from the expression

$$E y_1 = E' y_1' + P_n h$$

The problem is rendered statically determinate by assuming a relationship between the forces  $E$  and  $X$  of the form

$$X = \lambda f(x) E \quad (9.13)$$

where  $f(x)$  is a function chosen to represent the pattern of variation of the ratio  $X/E$  across the failure mass and  $\lambda$  is a scale factor. The value of  $\lambda$  is obtained as part of the solution along with the factor of safety  $F$ .

To obtain a solution the soil mass above a trial failure surface is divided into a series of slices of finite width such that the failure surface within each slice can be assumed to be linear. The boundary conditions at each end of the failure surface are in terms of the force  $E$  and a moment  $M$  which is given by the integral of an expression containing both  $E$  and  $X$ : normally both  $E$  and  $M$  are zero at each end of the failure surface. The method of solution involves choosing trial values of  $\lambda$  and  $F$ , setting the force  $E$  to zero at the beginning of the failure surface and integrating across each slice in turn, obtaining values of  $E$ ,  $X$  and  $y_1$ ; the resulting values of  $E$  and  $M$  at the end of the failure surface will in general not be zero. A systematic iteration technique, based on the Newton-Raphson method and described by Morgenstern and Price [13], is used to modify the values of  $\lambda$  and  $F$  until the resulting values of both  $E$  and  $M$  at the end of the failure surface are zero. The factor of safety is not significantly affected by the choice of the function  $f(x)$  and as a consequence  $f(x) = 1$  is a common assumption.

For any assumed failure surface it is necessary to examine the solution to ensure that it is valid in respect of the implied state of stress within the soil mass above that surface. Accordingly, a check is made to ensure that neither shear failure nor a state of tension is implied within the mass. The first condition is satisfied if the available shearing resistance on each vertical interface is greater than the corresponding value of the force  $X$ : the ratio of these two forces represents the local factor of safety against shear failure along the interface. The requirement that no tension should be developed is satisfied if the line of thrust of the  $E$  forces, as given by the computed values of  $y_1$ , lies wholly above the failure surface.

Computer software for the Morgenstern-Price analysis is readily available. The method can be fully exploited if an interactive approach, using computer graphics, is adopted.

Bell [1] proposed a method of analysis in which all the conditions of equilibrium are satisfied and the assumed failure surface may be of any shape. The soil mass is divided into a number of vertical slices and statical determinacy is obtained by means of an assumed distribution of normal stress along the failure surface.

Sarma [15] developed a method, based on the method of slices, in which the critical earthquake acceleration required to produce a condition of limiting equilibrium is



determined. An assumed distribution of vertical interslice forces is used in the analysis. Again, all the conditions of equilibrium are satisfied and the assumed failure surface may be of any shape. The static factor of safety is the factor by which the shear strength of the soil must be reduced such that the critical acceleration is zero.

The use of a computer is also essential for the Bell and Sarma methods and all solutions must be checked to ensure that they are physically acceptable.



## END-OF-CONSTRUCTION AND LONG-TERM STABILITY

### Excavated slopes

When a slope is formed by excavation, the decreases in total stress result in changes in pore water pressure in the vicinity of the slope and, in particular, along a potential failure surface. For the case illustrated in Figure 9.9, the initial pore water pressure ( $u_0$ ) depends on the depth of the point in question below the initial (static) water table (i.e.  $u_0 = u_s$ ). The change in pore water pressure ( $\Delta u$ ) due to excavation is given theoretically by Equation 4.25 or 4.26. After excavation, pore water will flow towards the slope and drawdown of the water table will occur: a steady seepage condition will become established for which a flow net can be drawn. The final pore water pressure ( $u_f$ ), after dissipation of excess pore water pressure is complete, will be the steady seepage value determined from the flow net (i.e.  $u_f = u_{ss}$ ).

If the permeability of the soil is low, a considerable time will elapse before any significant dissipation of excess pore water pressure will have taken place. At the end of construction the soil will be virtually in the undrained condition and a total stress analysis will be relevant. In principle an effective stress analysis is also possible for the end-of-construction condition using the appropriate value of pore water pressure ( $u_0 + \Delta u$ ) for this condition. However, because of its greater simplicity, a total stress analysis is generally used. It should be realized that the same factor of safety will not generally be obtained from a total stress and an effective stress analysis of the

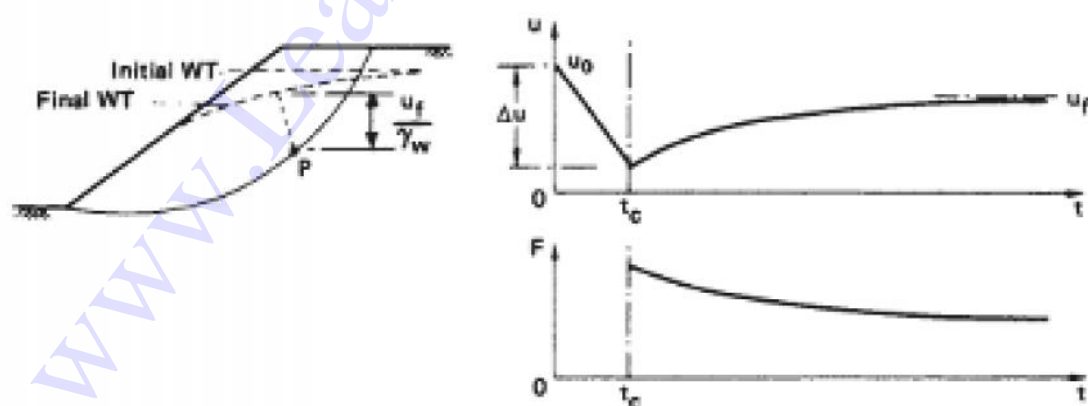
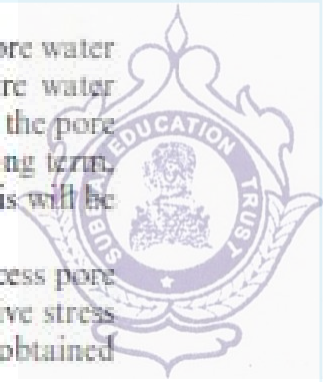

Figure 9.9 Pore pressure dissipation and factor of safety after excavation. (Reproduced from A.W. Bishop and L. Bjerrum (1960) *Proceedings ASCE Research Conference on Shear Strength of Cohesive Soils*, Boulder, Colorado, by permission of the American Society of Civil Engineers.)



end-of-construction condition. In a total stress analysis it is implied that the pore water pressures are those for a failure condition (being the equivalent of the pore water pressure at failure in an undrained triaxial test): in an effective stress analysis the pore water pressures used are those predicted for a non-failure condition. In the long term, the fully drained condition will be reached and only an effective stress analysis will be appropriate.

On the other hand, if the permeability of the soil is high, dissipation of excess pore water pressure will be largely complete by the end of construction. An effective stress analysis is relevant for all conditions with values of pore water pressure being obtained from the static water table level or the steady seepage flow net.

It is important to identify the most dangerous condition in any practical problem in order that the appropriate shear strength parameters are used in design.

Equation 4.25, with  $B = 1$  for a fully saturated clay, can be rearranged as follows:

$$\Delta u = \frac{1}{2}(\Delta\sigma_1 + \Delta\sigma_3) + \left(A - \frac{1}{2}\right)(\Delta\sigma_1 - \Delta\sigma_3)$$

For a typical point P on a potential failure surface (Figure 9.9) the first term in Equation 9.14 is negative and the second term will also be negative if the value of  $A$  is less than 0.5. Overall, the pore water pressure change  $\Delta u$  is negative. The effect of the rotation of the principal stress directions is neglected. As dissipation proceeds the pore water pressure increases to the steady seepage value as shown in Figure 9.9. The factor of safety will therefore have a lower value in the long term, when dissipation is complete, than at the end of construction.

Slopes in overconsolidated fissured clays require special consideration. A number of cases are on record in which failures in this type of clay have occurred long after dissipation of excess pore water pressure had been completed. Analysis of these failures showed that the average shear strength at failure was well below the peak value. It is probable that large strains occur locally due to the presence of fissures, resulting in the peak strength being reached, followed by a gradual decrease towards the critical-state value. The development of large local strains can lead eventually to a progressive slope failure. However, fissures may not be the only cause of progressive failure: there is considerable non-uniformity of shear stress along a potential failure surface and local overstressing may initiate progressive failure. It is also possible that there could be a pre-existing slip surface in this type of clay and that it could be reactivated by excavation. In such cases a considerable slip movement could have taken place previously, sufficiently large for the shear strength to fall below the critical-state value and towards the residual value.

Thus for an initial failure (a 'first time' slip) in overconsolidated fissured clay the relevant strength for the analysis of long-term stability is the critical-state value. However, for failure along a pre-existing slip surface the relevant strength is the residual value. Clearly it is vital that the presence of a pre-existing slip surface in the vicinity of a projected excavation should be detected during the ground investigation.

The strength of an overconsolidated clay at the critical state, for use in the analysis of a potential first time slip, is difficult to determine accurately. Skempton [17] has suggested that the maximum strength of the remoulded clay in the normally consolidated condition can be taken as a practical approximation to the strength of the

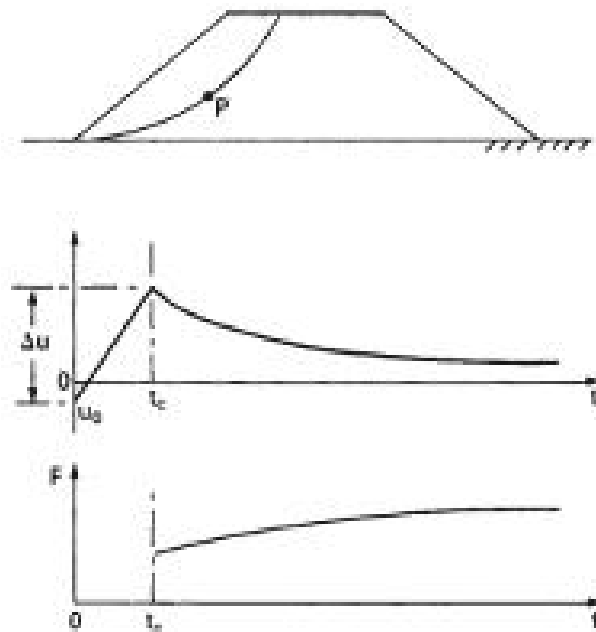

Figure 9.10 Pore pressure dissipation and factor of safety in an embankment.

overconsolidated clay at the critical state, i.e. when it has fully softened adjacent to the slip plane as the result of expansion during shear.

## Embankments

The construction of an embankment results in increases in total stress, both within the embankment itself as successive layers of fill are placed and in the foundation soil. The initial pore water pressure ( $u_0$ ) depends primarily on the placement water content of the fill. The construction period of a typical embankment is relatively short and, if the permeability of the compacted fill is low, no significant dissipation is likely during construction. Dissipation proceeds after the end of construction with the pore water pressure decreasing to the final value in the long term, as shown in Figure 9.10. The factor of safety of an embankment at the end of construction is therefore lower than in the long term. Shear strength parameters for the fill material should be determined from tests on specimens compacted to the values of dry density and water content to be specified for the embankment.

The stability of an embankment may also depend on the shear strength of the foundation soil. The possibility of failure along a surface such as that illustrated in Figure 9.11 should be considered in appropriate cases.

## EMBANKMENT DAMS

An embankment dam would normally be used where the foundation and abutment conditions were unsuitable for a concrete dam and where suitable materials for the embankment were present at or close to the site. An extensive ground investigation is essential, general at first but becoming more detailed as design studies proceed, to

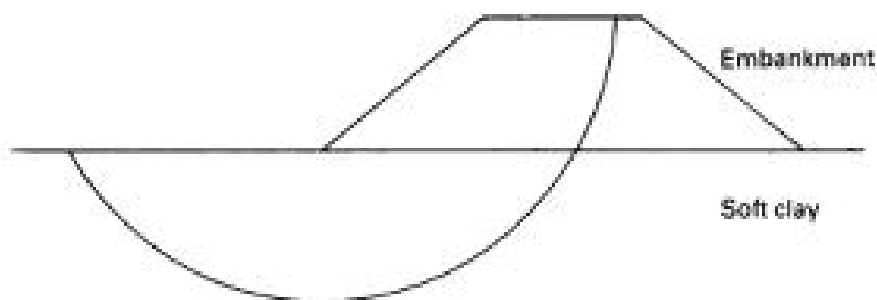

Figure 9.11 Failure below an embankment.

determine foundation and abutment conditions and to identify suitable borrow areas. It is important to determine both the quantity and quality of available material. The natural water content of fine soils should be determined for comparison with the optimum water content for compaction.

Most embankment dams are not homogeneous but are of zoned construction, the detailed section depending on the availability of soil types. Typically a dam will consist of a core of low-permeability soil with shoulders of other suitable material on each side. The upstream slope is usually covered by a thin layer of rockfill (known as rip-rap) to protect it from erosion by wave action. The downstream slope is usually grassed. An internal drainage system, to alleviate the detrimental effects of seeping water, would normally be incorporated. Depending on the materials used, horizontal drainage layers may also be incorporated to accelerate the dissipation of excess pore water pressure. Slope angles should be such that stability is ensured but overconservative design must be avoided: a decrease in slope angle of as little as  $2-3^\circ$  (to the horizontal) would mean a significant increase in the volume of fill for a large dam.

Failure of an embankment dam could result from the following causes: (1) instability of either the upstream or downstream slope, (2) internal erosion and (3) erosion of the crest and downstream slope by overtopping. (The third cause arises basically from errors in the hydrological predictions.)

The factor of safety for both slopes must be determined as accurately as possible for the most critical stages in the life of the dam. The potential failure surface may lie entirely within the embankment or may pass through the embankment and the foundation soil. In the case of the upstream slope the most critical stages are at the end of construction and during rapid drawdown of the reservoir level. The critical stages for the downstream slope are at the end of construction and during steady seepage when the reservoir is full. The pore water pressure distribution at any stage has a dominant influence on the factor of safety of the slopes and it is common practice to install a piezometer system so that the actual pore water pressures can be measured and compared with the predicted values used in design (provided an effective stress analysis has been used). Remedial action could then be taken if the factor of safety, based on the measured values, was considered to be too low.

The Morgenstern-Price analysis is the most appropriate because of its inherent accuracy and because it can deal with non-circular failure surfaces. Values of the parameters  $c'$ ,  $\phi$ ,  $r_u$  and  $\gamma$  are required for each soil zone. However, it must be

recognized that although the analysis itself is accurate, the values of factor of safety produced depend on the correctness of the parameters used.

If a potential failure surface were to pass through foundation material containing fissures, joints or pre-existing slip surfaces, then progressive failure (Section 9.6) would be a possibility. The different stress-strain characteristics of various zone materials through which a potential failure surface passes, together with non-uniformity of shear stress, could also lead to progressive failure.

Another problem is the danger of cracking due to differential movements between soil zones and between the dam and the abutments. The possibility of hydraulic fracturing, particularly within the clay core, should also be considered. Hydraulic fracturing occurs on a plane where the total normal stress is less than the local value of pore water pressure. Following the completion of construction the clay core tends to settle relative to the rest of the embankment due to long-term consolidation; consequently the core will be partially supported by the rest of the embankment. Thus vertical stress in the core will be reduced and the chances of hydraulic fracture increased. The transfer of stress from the core to the shoulders of the embankment is another example of the arching phenomenon (Section 6.7). Following fracture or cracking the resulting leakage could lead to serious internal erosion and impair stability. The finite element method has been used to predict the stresses and deformations within embankment dams, enabling potential areas of cracking and fracture to be predicted.

### End of construction

Most slope failures in embankment dams occur either during construction or at the end of construction. Pore water pressures depend on the placement water content of the fill and on the rate of construction. A commitment to achieve rapid completion will result in the maximization of pore water pressure at the end of construction. However, the construction period of an embankment dam is likely to be long enough to allow partial dissipation of excess pore water pressure, especially for a dam with internal drainage. A total stress analysis, therefore, would result in an overconservative design. An effective stress analysis is preferable, using predicted values of  $r_u$ . An upper bound value of  $r_u$  can be deduced.

The pore pressure ( $u$ ) at any point can be written as

$$u = u_0 + \Delta u$$

where  $u_0$  is the initial value and  $\Delta u$  the change in pore water pressure under undrained conditions. In terms of the change in total major principal stress

$$u = u_0 + B \Delta \sigma_1$$

Then

$$r_u = \frac{u_0}{\gamma h} + B \frac{\Delta \sigma_1}{\gamma h}$$

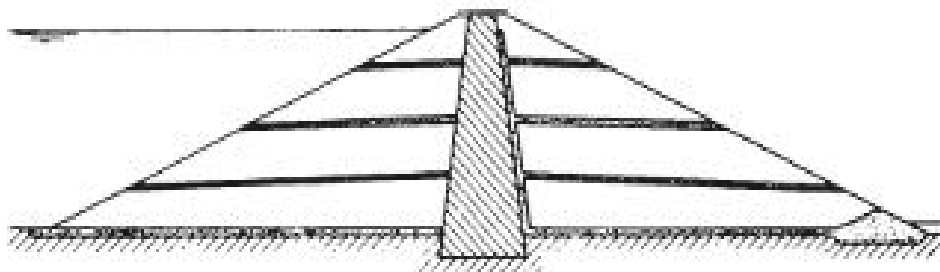

Horizontal drainage layers.



If it is assumed that the increase in total major principal stress is approximately equal to the fill pressure along a potential failure surface

$$r_u = \frac{u_0}{\gamma h} + B$$

The soil is partially saturated when compacted and therefore the initial pore water pressure ( $u_0$ ) is negative. The actual value of  $u_0$  depends on the placement water content; the higher the water content, the closer the value of  $u_0$  to zero. The value of  $B$  also depends on the placement water content; the higher the water content, the higher the value of  $B$ . Thus, for an upper bound

$$r_u = B$$

The value of  $B$  must correspond to the stress conditions in the dam. Equations 9.15 and 9.16 assume no dissipation during construction. A factor of safety as low as 1.3 may be acceptable at the end of construction provided there is reasonable confidence in the design data.

If high values of  $r_u$  are anticipated, dissipation of excess pore water pressure can be accelerated by means of horizontal drainage layers incorporated in the dam, drainage taking place vertically towards the layers: a typical dam section is shown in Figure 9.12. The efficiency of drainage layers has been examined theoretically by Gibson and Shefford [9] and it was shown that in a typical case the layers, in order to be fully effective, should have a permeability at least  $10^6$  times that of the embankment soil: an acceptable efficiency would be obtained with a permeability ratio of about  $10^5$ .

### Steady seepage

After the reservoir has been full for some time, conditions of steady seepage become established through the dam with the soil below the top flow line in the fully saturated state. This condition must be analysed in terms of effective stress with values of pore pressure being determined from the flow net. Values of  $r_u$  up to 0.45 are possible in homogeneous dams but much lower values can be achieved in dams having internal drainage. The factor of safety for this condition should be at least 1.5. Internal erosion is a particular danger when the reservoir is full because it can arise and develop within a relatively short time, seriously impairing the safety of the dam.

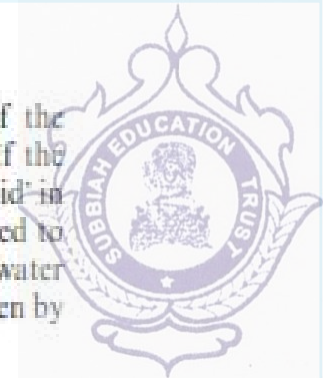

### Rapid drawdown

After a condition of steady seepage has become established, a drawdown of the reservoir level will result in a change in the pore water pressure distribution. If the permeability of the soil is low, a drawdown period measured in weeks may be 'rapid' in relation to dissipation time and the change in pore water pressure can be assumed to take place under undrained conditions. Referring to Figure 9.13, the pore water pressure before drawdown at a typical point P on a potential failure surface is given by

$$u_0 = \gamma_w(h + h_w - h')$$

where  $h'$  is the loss in total head due to seepage between the upstream slope surface and the point P. It is again assumed that the total major principal stress at P is equal to the fill pressure. The change in total major principal stress is due to the total or partial removal of water above the slope on the vertical through P. For a drawdown depth exceeding  $h_w$ :

$$\Delta\sigma_1 = -\gamma_w h_w$$

and the change in pore water pressure is then given by

$$\begin{aligned}\Delta u &= B \Delta\sigma_1 \\ &= -B\gamma_w h_w\end{aligned}$$

Therefore the pore water pressure at P immediately after drawdown is

$$\begin{aligned}u &= u_0 + \Delta u \\ &= \gamma_w(h + h_w(1 - B) - h')\end{aligned}$$

Hence

$$\begin{aligned}r_u &= \frac{u}{\gamma_{sat}h} \\ &= \frac{\gamma_w}{\gamma_{sat}} \left\{ 1 + \frac{h_w}{h} (1 - B) - \frac{h'}{h} \right\}\end{aligned}$$

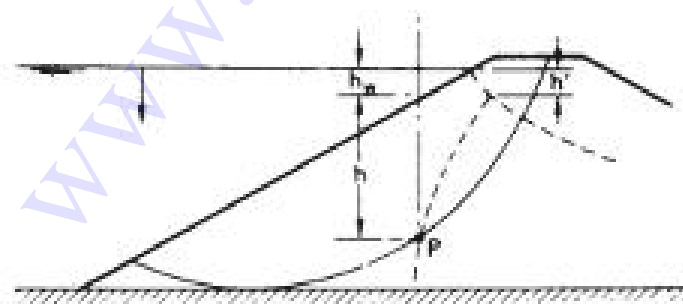

Rapid drawdown conditions. (Reproduced from A.W. Bishop and L. Bjerrum (1960) *Proceedings ASCE Research Conference on Shear Strength of Cohesive Soils*, Boulder, Colorado, by permission of the American Society of Civil Engineers.)

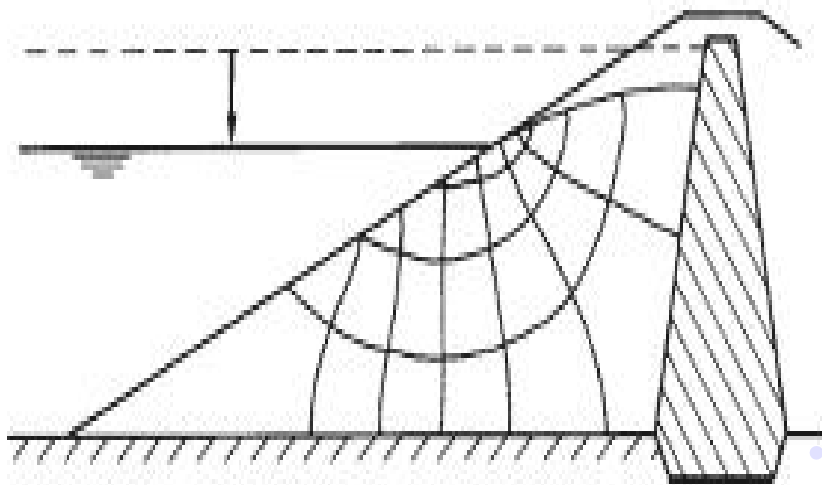

Figure 9.14 Drawdown flow net.

For total stress decreases the value of  $\bar{B}$  is slightly greater than 1. An upper bound value of  $r_u$  could be obtained by assuming  $\bar{B} = 1$  and neglecting  $h'$ . Typical values of  $r_u$  immediately after drawdown are within the range 0.3–0.4. A minimum factor of safety of 1.2 may be acceptable after rapid drawdown.

Morgenstern [11] published stability coefficients for the approximate analysis of homogeneous slopes after rapid drawdown.

The pore water pressure distribution after drawdown in soils of high permeability decreases as pore water drains out of the soil above the drawdown level. The saturation line moves downwards at a rate depending on the permeability of the soil. A series of flow nets can be drawn for different positions of the saturation line and values of pore water pressure obtained. The factor of safety can thus be determined, using an effective stress analysis, for any position of the saturation line. An example of a drawdown flow net is shown in Figure 9.14.